

TROUBLESHOOTING INSTRUCTIONS

PROBLEMS	SOLUTIONS
A. Lubricant will not bleed through the BLEEDER VALVE when the button is held down.	<ol style="list-style-type: none"> If none of the EJECTORS will bleed. <ol style="list-style-type: none"> The FLUID ON/OFF VALVE may be closed. Open by turning the knob counter-clockwise. The Lubricant Reservoir may be low or empty. Fill Reservoir until above top of EJECTOR. The lubricant may be too viscous to flow through. If one EJECTOR will not bleed. <ol style="list-style-type: none"> The INLET CHECK VALVE may be clogged or stuck closed. See "Inspecting an EJECTOR" on page 6.
B. UniVALVE will not cycle when ACTUATOR is tripped.	<ol style="list-style-type: none"> Ascertain if the problem is with the UniVALVE or ACTUATOR. <ol style="list-style-type: none"> Disconnect or turn off the AIR SUPPLY to the UNIT. Remove the ACTUATOR from the UNIT by disconnecting it at the RELIEF PORT of the UniVALVE. This connection varies with the type of ACTUATOR used (see the INSTRUCTIONS for the ACTUATOR). After disconnecting the ACTUATOR, turn the AIR SUPPLY back on again. With the air on, there should be a light flow of air from the RELIEF PORT. If not, the UniValve is at fault, go to Step #5 below. Stop this air flow by plugging the RELIEF PORT with your thumb or by using a pipe plug. When this air flow is stopped, the UNIT should actuate (for re-charging). When this restriction is removed, the UNIT should actuate again (for ejection). If the UNIT does actuate, the problem is with the ACTUATOR. See the INSTRUCTIONS supplied with the type of ACTUATOR you are using and continue per it's instruction. If the UNIT does not actuate, re-connect the ACTUATOR per it's INSTRUCTIONS and continue below. Check the operating air pressure, it may be set too low. It should be at least 40 PSI or higher. If an ACTUATOR TUBE is being used, and if it is longer than four feet, response may be slow. If it is too long, the UniVALVE will not operate. Also, check this Tube for cracks, leakage and poor connections. The UniVALVE may require lubrication. Check the AIR LINE OILER for function. The UniVALVE may need cleaning or repair. See "INSPECTING A UniVALVE" on page 5.
C. The spray pattern from the NOZZLE ASSEMBLY is unsatisfactory. EXAMPLE: Poor dispersion, after drip, etc.	<ol style="list-style-type: none"> Prime the appropriate EJECTOR. See OPERATING INSTRUCTIONS at Step C. If this solves the problem; but it returns often, go to PROBLEM "D" below. The VELOCITY CONTROL and/or the AIR REGULATOR may be set too low. Open by turning the knobs of these controls counter-clockwise. Check per Inspecting the DISTRIBUTION SYSTEM on page 7. Air may be "trapped" in the system. See OPERATING INSTRUCTIONS at Step H. Check the Inlet/Outlet Checks in the EJECTOR per Inspecting an EJECTOR on page 6.
D. The EJECTOR requires continual re-priming to maintain good performance. This is a sign that air is being drawn into the System.	<ol style="list-style-type: none"> If the System has been newly installed, the fittings on the FLUID SUPPLY LINE may not have been made air tight. Check these connections. This is probably not the problem if the System has been in use for a while. The "O"Rings sealing the EJECTOR to the Manifold, or a seal inside the EJECTOR may be worn or contaminated. See Inspecting an EJECTOR on page 6.
E. Fluid is being expelled from the relief hole in front of the EJECTOR.	<ol style="list-style-type: none"> The "O"Ring sealing the Ram inside the EJECTOR is worn or contaminated. See Inspecting an EJECTOR on page 6.
F. No fluid is ejected from the NOZZLE	<ol style="list-style-type: none"> If all the EJECTORS are failing to dispense fluid. <ol style="list-style-type: none"> Fluid may not be present. See PROBLEM "A" at Step #1 above. The UniVALVE may not be operating. If not, see PROBLEM "B" above. If one of the EJECTORS is failing to dispense fluid. <ol style="list-style-type: none"> Prime the EJECTOR. See OPERATING INSTRUCTIONS at Step "C". The VELOCITY CONTROL and/or the VOLUME CONTROL may be shut down. Open by turning the knobs of these controls counter-clockwise. Ascertain if the problem is with the EJECTOR or the DISTRIBUTION SYSTEM. Remove the DISTRIBUTION LINE from the OUTLET PORT on the EJECTOR, and operate the UNIT. If an appropriate amount of fluid is forcefully ejected from the OUTLET PORT, there is probably a clog in the DISTRIBUTION SYSTEM. See Inspecting the DISTRIBUTION SYSTEM on page 7. If little or no fluid is ejected, or it is ejected with little force, the problem is with the EJECTOR. See Inspecting an EJECTOR on page 6.

INSTALLATION, OPERATION, and TROUBLESHOOTING

with **REPLACEMENT PARTS LISTING**
for PresSpray II Models P-152 and P-154



P.O.Box 5303, Rockford, IL • 61125
5060-27th Ave, Rockford, IL • 61109
Tel: 815-226-8090 • Fax: 815-226-9250
E-mail: sales@lspind.com

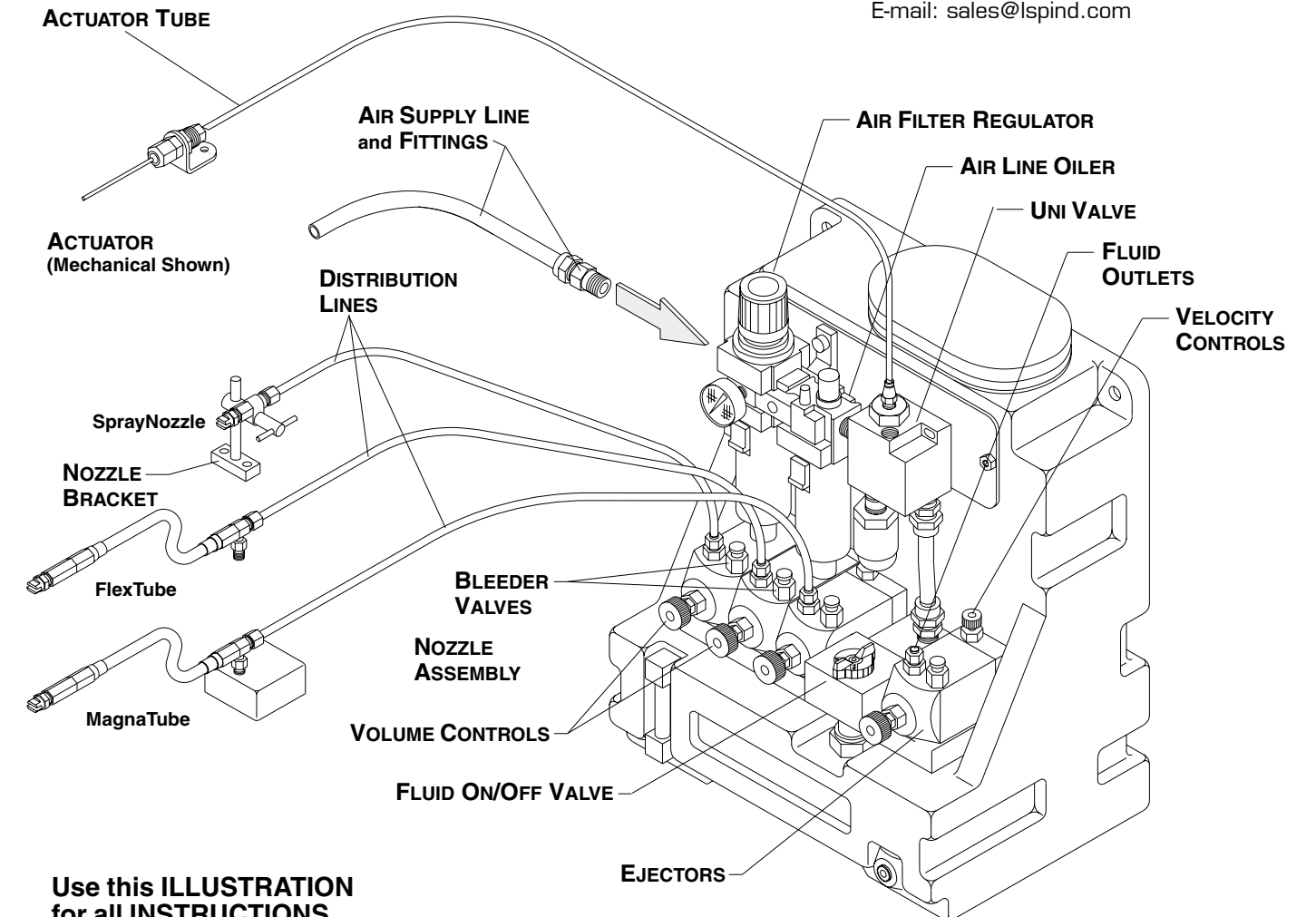

Use this **ILLUSTRATION**
for all **INSTRUCTIONS**

Items called out in the **ILLUSTRATION**
are identified in the **INSTRUCTIONS** by
ALL CAPITAL LETTERS

The term **UNIT** is used to designate
the entire PresSpray II

INSTALLATION INSTRUCTIONS

A. Installing the PresSpray II

1. Locating the UNIT

Locate the **UNIT** closer to the **ACTUATOR** for best response. Locate the **UNIT** closer to the **NOZZLE ASSEMBLY** for better spray quality. Locate the **UNIT** lower than the level of the **NOZZLE ASSEMBLY** for easier start-up.

2. Mounting the UNIT

The **UNIT** can be simply set in place, or be mounted on a wall or side of a machine using the holes provided.

B. Installing an Actuator

You must have an **ACTUATOR** to operate the **UNIT**. If you do not have one, see the **ACCESSORIES** area for a listing of the types of **ACTUATORS** available.

Install the **ACTUATOR** in accordance with the **OPERATING INSTRUCTION** supplied with the chosen **ACTUATOR**. For fastest response and cycling, have the **ACTUATOR** located at or on the **UNIT**.

11/24/13

OPERATING INSTRUCTIONS

C. Installing the DISTRIBUTION SYSTEM

This system consists of **NOZZLE ASSEMBLIES**, **DISTRIBUTION LINE**, and their connections with the **UNIT**.

1. Items required for the SYSTEM

a. NOZZLE ASSEMBLIES

Consist of **SPRAYNOZZLES**, **FLEXTUBES**, **MAGNATUBES**, **NPT NOZZLES**, or **INDIENOZZLES**. Use one **NOZZLE** per **EJECTOR**.

b. DISTRIBUTION LINE

Carries lubricant to be sprayed to the **NOZZLE ASSEMBLIES**. Tubing must be 1/4" in diameter. For best spray quality, use metal tubing. Soft copper is the easiest to handle.

For flexible **DISTRIBUTION LINE**, use only **HyPressure Tubing** (see **ACCESSORIES**). Any other flexible tubing will give poor spray quality and/or may burst.

c. LINE FITTINGS

NOZZLES and **EJECTORS** have built-in connections of the "Compression Fitting" type. Use the same type fittings for running **DISTRIBUTION LINES**.

2. Mounting the NOZZLES ASSEMBLIES

a. SPRAYNOZZLES

Require support. Metal **DISTRIBUTION LINE** can be used for this if anchored close to the **SPRAYNOZZLE**. With flexible **LINE**, a **NOZZLEBRACKET** will be required for support.

b. FLEXTUBES

Install into a tapped hole. Drill and tap for 1/8-27 pipe thread at the desired location. Screw **FLEXTUBE** into hole.

c. MAGNATUBES

Simply set in place on an iron surface. A powerful magnetic base is used to hold the **MAGNATUBE** in place.

d. INDIENOZZLE

These **NOZZLES** require special attention. Call **L.S.P.** or our representative for advice if planning to use **INDIENOZZLES**.

e. NPT Nozzles

These **NOZZLES** thread directly into a 1/8-27 NPT tapped hole or fitting. Use thread sealant when installing.

3. Installing the Distribution Lines

- Keep length of all **LINES** to a minimum. Run each **LINE** as directly as possible, use no slack unless necessary.
- Use metal tubing wherever possible. If flexible **LINE** must be used, use metal as far as possible and continue with flexible **LINE**, using it only where needed.
- Keep contamination out of the **LINES**. Have the tubing clean on the inside before installing.
- Make all connections properly. **LINE** must be bottomed in fittings while nut is tightened to hand-tight and then one full turn further.

D. Installing the Air Supply

The **UNIT** operates on compressed air in extremely fast bursts. The line supplying this air must not restrict its flow. The chart below gives the minimum air passages for the **AIR SUPPLY LINE & FITTINGS** depending on how many **EJECTORS** are on the **UNIT**.

No. of Ejectors	Tube I.D. (not O.D.)	Pipe Size & Fittings
1 or 2	3/16" (.187)	1/8" N.P.T.
3 or 4	1/4" (.250)	1/4" N.P.T.
5 to 6	5/16" (.312)	3/8" N.P.T.

NOTE: Increase passage by one size if using an elbow fitting, or line is over 10 feet long.

Run the appropriately sized **AIR SUPPLY LINE** from your compressed air supply and connect it to the open port in the **AIR REGULATOR** on the **UNIT**.

Fill the **AIRLINE OILER** with light machine oil.

A. Supply the Fluid to be Sprayed

Fill the **RESERVOIR** with the lubricant to be sprayed. Fill until fluid level is higher than the top of the **EJECTOR**.

B. Open the Fluid ON/OFF VALVE

Turn the knob of **ON/OFF VALVE** counter-clockwise to full open.

C. Prime the EJECTORS

Press down on **BLEED VALVE** located on top of each **EJECTOR**. Hold down until the fluid flowing from the hole in the side of this **VALVE** is void of air bubbles.

D. Supply Operating Air

Connect or turn on the **AIR SUPPLY** to the **UNIT**.

E. Open the Controls

Fully open the **VELOCITY CONTROL** and **VOLUME CONTROL** by turning their knobs counter-clockwise. Fully open the **AIR REGULATOR** by turning its knob clockwise.

F. Operate the UNIT

Cycle the **UNIT** until the **DISTRIBUTION LINES** fill and the **NOZZLES** begin to eject lubricant. The spray pattern will be of poor quality and will drip until all air is ejected from the **SYSTEM**. Continue cycling until spray is a sharp burst with no drips. If there are problems, go to **step H**. below.

G. Make Adjustments

NOTE: Before making any adjustments, the **SYSTEM** should be operating at optimum or these adjustments may change.

1. Aim the Nozzles

Position **NOZZLE(s)** to achieve the desired spray coverage.

2. Reduce the amount of Fluid used.

Turn the **VOLUME CONTROL** clockwise to reduce the amount of lubricant being sprayed to the amount desired.

3. Reduce the Operating Air Pressure.

Using the **AIR REGULATOR**, reduce pressure until:

- Spray quality deteriorates, then increase 10 PSI and operate.
- Unit begins to malfunction, then increase 10 PSI and operate.
- Air regulator shows 40 PSI. This is the minimum recommended pressure for the operation of this equipment. Operating under these conditions gives power with economical air consumption.

4. Set the VELOCITY CONTROL

Turn the **VELOCITY CONTROL** clockwise to reduce the intensity of the spray burst. Used to control lubricant over-spray and bounce.

5. Adjust the AIRLINE OILER

Turn knob at top of **AIRLINE OILER** to adjust its usage to one drop of oil every 10 to 15 cycles.

H. Purging the DISTRIBUTION LINES

If inferior spray or dripping from the **NOZZLES** persists, one of the following situations may be the cause.

1. Incorrect DISTRIBUTION LINE

The problem may be due to using improper **DISTRIBUTION LINE**. If the **LINE** is too "soft", it will expand at ejection and absorb the burst of pressure required for a good spray. After the spray, the **LINE** contracts again to squeeze out a drip. The longer the **LINE**, the worse the effect. Even **HYPRESSURE TUBE** will do this if too long a length is used.

PARTS LIST "E"

USE THE APPROPRIATE FIGURE AT THE RIGHT TO IDENTIFY THE PART BY IT'S KEY NO.

USING THE KEY NO. AND TABLE BELOW, FIND THE PART NUMBER, NO. OF PIECES USED, AND THE DESCRIPTION OF THE PART NEEDED.

KEYPART	NO.	DESCRIPTION
NOZ-101	1	NOZZLE, 110° FAN:
NOZ-102	1	NOZZLE, 80° FAN:
1 NOZ-103	1	NOZZLE, 65° FAN:
NOZ-104	1	NOZZLE, 25° FAN:
NOZ-105	1	NOZZLE, 55° ROUND:
NOZ-106	1	NOZZLE, SIDE FAN:
2 SPG-005	1	SPRING,CHECK:
3 EYE-001	1	EYELET,CHECK
4 BAL-021	1	BALL,CHECK:
5 SET-019	1	SEAT,CHECK:
6 280-SPG-01	1	SPRING ASSEMBLY:
7 BAL-022	1	BALL,CHECK:
8 HSG-050	1	HOUSING,CHECK
9 HSG-020	1	HOUSING,CHECK
10 FIT-017	1	FITTING,NUT:
11 290-BRK-02	1	BRACKET ASSY:
12 HSG-036	1	HOUSING,CHECK:
13 RGO-006	2	O-RING,SEAL:
14 RGB-006	2	RING,BACKUP:
15 281-TUB-01	1	FLEXTUBE ASSY:
16 TUB-011	1	TUBE,COPPER:
17 ADP-041	1	ADAPTER,MOUNTING:
18 BRK-014	1	BRACKET,MOUNTING
18 BRK-014	1	BRACKET,MOUNTING
19 282-BAS-07	1	MAGNETIC BASE
22 SCR022	1	SCREW, BUTTON Hd: 10X32-.875
23 290BAS05	1	MAGNETIC BASE

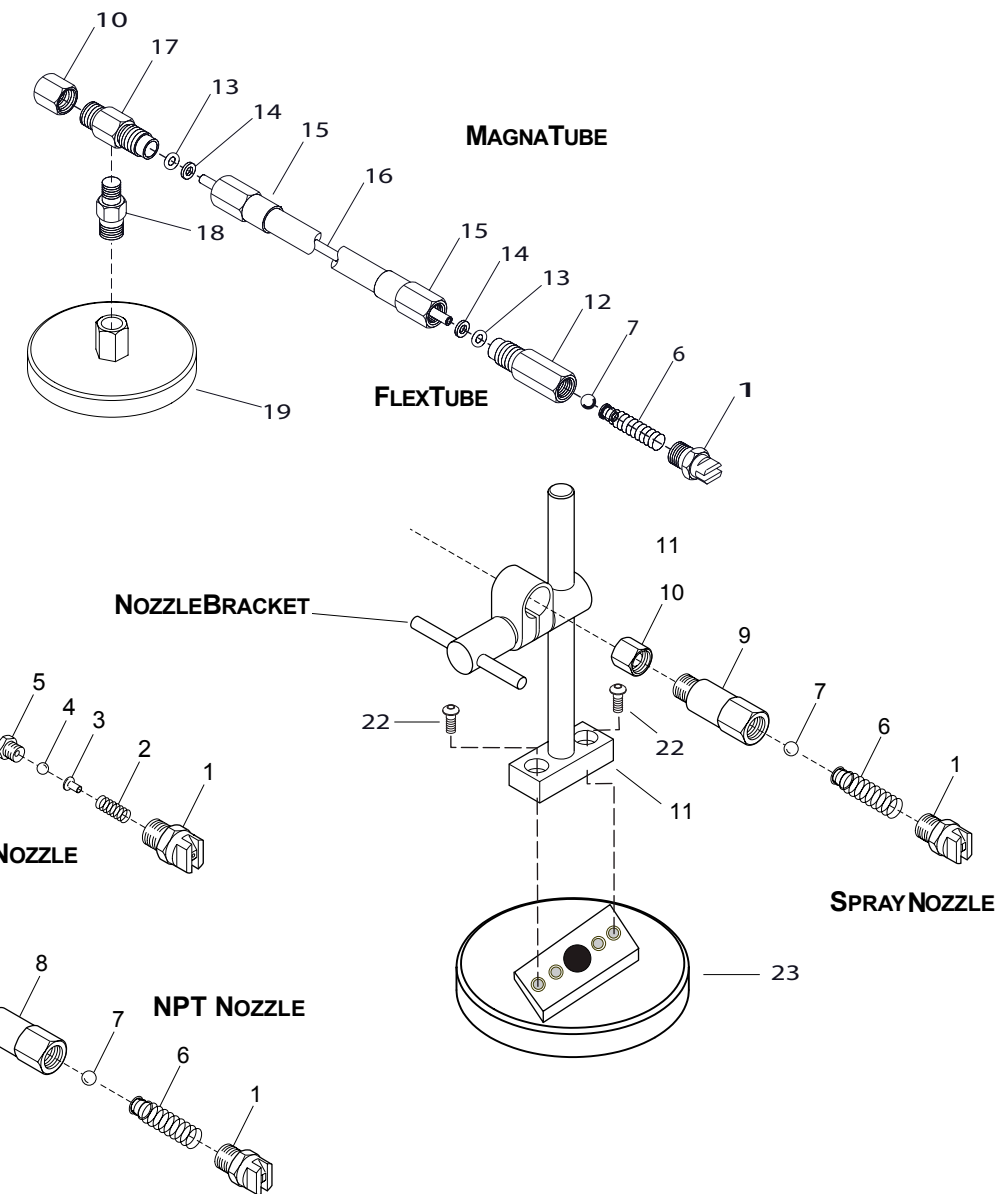

Inspecting the Distribution System Refer to **PARTS LIST "E"** for Key No's shown in parenthesis.

A. The DISTRIBUTION LINE

This **LINE** is very important to good performance. Check that it is of the proper type. See **INSTALLATION INSTRUCTIONS** at **Step "D"**.

If this **LINE** is metal, check for kinks or crimping that may have closed it off. If it is flexible **LINE**, check it for cuts or cracks.

In either case, check all connections to insure they are air tight.

B. The NOZZLE TIP

NOTE: Whenever a Nozzle Tip (#1) is removed, the Check Ball (#4, #7) should be replaced. In time, the Ball takes a "set" and will not seat properly once disturbed.

- Unscrew the Nozzle Tip (#1). Caution, this Tip is spring loaded.
- Inspect the Check Spring (#2, #6). Replace if broken or deformed.
- Clean the Nozzle Tip (#1) and blow dry. Inspect by looking through it. If you do not see a tiny, uniformly shaped hole, there is a clog.

Tips on unclogging a Nozzle Tip:

...Try to dislodge it with a high pressure stream directed backward to the normal flow through the Nozzle.

...If you must use a tool, use one as "soft" as possible (plastic, fiber)

...Apply no more pressure than necessary. The Tip is easily damaged.

Some clogs are impossible to get out without harming the Tip. Keep a spare Nozzle Tip handy for such cases.

- At re-assembly, clean the Nozzle Tip of all residue and apply thread sealant. Torque to 80-120 in.lbs.

C. The FLEXTUBE \ MAGNATUBE

A **FlexTube** or **MagnaTube** may be clogged or leaking. These problems are handled differently as described below.

1. Checking for a clogged FlexTube.

First do Step "B" above. Do no more dis-assembly. Check for the clog by running a wire or blowing through the Copper Tube (#16).

2. Repairing a leaking FlexTube.

- Unscrew the Check Housing (#12) from the FlexTube (#15).

NOTE: Removing the Nozzle Tip (#1) is not necessary.

- Unscrew the FlexTube (#15) from the Mounting Adapter (#17).
- Remove the two small "O"Rings(#13) and Backup Rings(#14). See if they are dirty, cut, or deformed. Clean or replace as needed.
- Check the surfaces where these "O"Rings seal. If scratched or marred, have smoothed or replace the part.
- Re-assemble in reverse order, and torque parts to 60-80 in.lbs.

NOTE: Do not remove the Copper Tube (#16) from FlexTube (#15) unless one or the other needs replacing. If it is necessary, be careful to not mar the soft Copper Tube which is easily scratched.

Removing an EJECTOR

A. Remove the AIR SUPPLY

For safety sake, disconnect the AIR SUPPLY to the UNIT.

B. Close the FLUID ON/OFF VALVE

Turn the Fluid On/Off Valve clockwise until shut down. If this is not done, fluid will spill out when the EJECTOR is removed.

C. Remove the EJECTOR

1. Disconnect DISTRIBUTION LINE from the OUTLET on the EJECTOR.
2. Remove two Screws on top of EJECTOR which hold it to the Manifold.
3. Lift the EJECTOR from the Manifold. Be careful doing this, so as not to lose either of the "O" Rings that seal between the two.

D. Re-Placement of EJECTOR

1. Replace the EJECTOR with another, or a CoverPlate (see ACCESSORIES), or with the same EJECTOR after being repaired.
2. Make sure the "O"Rings that seal between the EJECTOR and Manifold are clean, in good condition, and properly located into the grooves of the pilot bosses.
3. Torque the Screws which hold the EJECTOR (or CoverPlate) to the Manifold to 80-100 in.lbs.

NOTE: If you use a Cover Plate, use the Screws supplied with it instead of those for an EJECTOR.

PARTS LIST "D"

The Ejector (reference Fig #7)

Key Part No.	No. Pcs	Description -or- Part Name
1	1	BARREL, Ejector:
* 2	1	"O" RING, Seal:
* 3	1	RING, Backup:
4	1	VOLUME SCREW:
* 5	1	CHECK, Inlet:
* 6	1	"O" RING, Seal:
* 7	4	"O" RING, Seal:
8	1	INLET, Fluid:
* 9	1	BALL, Check:
*10	1	EYELKET, Flanged:
* 11	1	SPRING, Check
12	1	OUTLET, Fluid:
* 13	1	FITTING, Nut:
14	1	BLEEDER VALVE:
* 15	2	SPRING, Return:
* 16	1	BACKUP, Seal:
* 17	1	GUIDE ASSEMBLY:
* 18	1	"O" RING: Seal:
19	1	PISTON ASSEMBLY:
20	1	CYLINDER, Air:
* 21	1	"O" RING, Seal:
* 22	1	"O" RING, Seal:
23	1	VELOCITY SCREW:
24	1	INLET, Air:
25	1	PLATE, End:
26	4	SCREW, Cap:

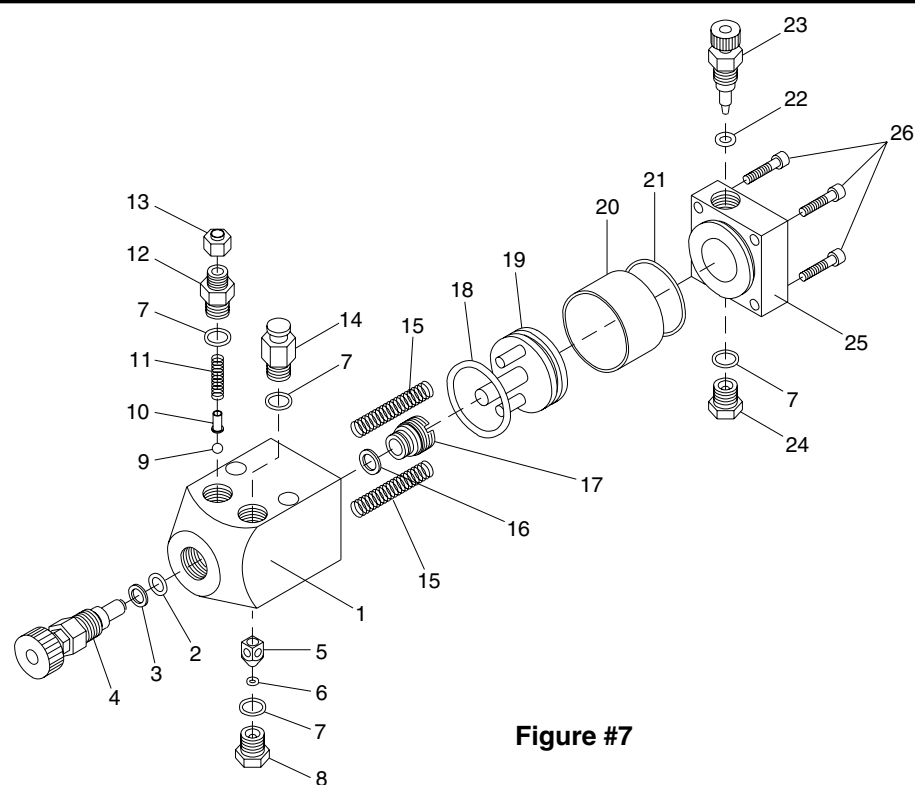

Figure #7

Inspecting an EJECTOR

Refer to PARTS LIST "D" for Key No's shown in parenthesis.

A. Placing the EJECTOR into a Vise

Clamp only on sides of the Barrel(#1) that have no fittings protruding.

B. The Inlet Check Valve

Allows fluid in from the FLUID SUPPLY. Inspect it as follows.

1. Unscrew the Inlet Adapter(#8) from the Barrel(#1).
2. Clean the Inlet(#8) and inspect the small "O"Ring(#6) inside. Do not remove this "O"Ring unless worn or broken. If it must be replaced, do not scratch the groove while removing it.
3. Check the movement of the Inlet Check. The Check Valve should fit closely in its cavity, yet move freely.
4. Inspect the rounded corners on the Check (the points at which it is guided in the cavity). These corners must be smooth and show no wear or deformation.
5. Inspect the Checks cavity for contamination or corrosion.

C. The Outlet Check Valve

Allows fluid out to the DISTRIBUTION LINE. Inspect it as follows.

1. Unscrew Outlet Fitting(#12) from the Barrel(#1). Caution, this part is spring loaded.
2. Inspect the Spring(#11). Replace if broken or deformed.
3. Inspect the Check Ball(#9). Replace if worn or deformed.

D. The Piston & Ram Assembly (#19)

Piston seals air used. Ram ejects the fluid sprayed. Inspect as follows.

1. Remove the four Screws(#26) holding End Plate(#25) to the Barrel(#1). Caution, this Plate is spring loaded.
2. The Return Springs may push the End Plate, Piston, and/or Cylinder from the Barrel. If not, remove by hand. If these parts are stuck, remove the Volume Control (#4) from the opposite end of the Barrel; this will allow access for pushing the parts out from that end.
3. Remove Piston & Ram Assy(#19), Cylinder(#20), and both Return Springs(#15). If a Spring is broken, be sure to remove all the pieces.
4. Remove the Guide Assembly (#17) using an LSP Tool #SP-935 or a very wide bladed screwdriver in the removal slot.
5. Clean and inspect all parts and seals. Replace worn, broken, or deformed parts, and worn, cut, or nicked seals.

E. Re-Assembly of the EJECTOR

Reverse the process above. Check the following.

1. If a new Guide Assembly (#17) is used it will come complete with the new O-Rings already installed and is ready for use. If the original Guide Assembly is re-installed make sure it is free of all residue and contamination.
2. Apply thread sealant before installing. Torque to 75-100 in.lbs.
3. Insure the side pins on Piston & Ram Assy (#20) are inserted into the Return Springs(#15). And that the center pin (the Ram) aligns with and slides into the Guide Assembly (#17).
4. Torque Screws(#26) in End Plate(#25) to 50 to 70 in.lbs.

OPERATING (continued)

2. Drawn-In Air

During operation the SYSTEM sees a vacuum. Any connection that is not air tight may allow air in. Use pipe sealant on all threads, and make all tube connections properly.

3. Introduced Air

If your lubricant container is left to run dry it will allow air into the SYSTEM. Such air will need to be purged again. See steps C. and F. above.

Example #1:

If a portion of the SYSTEM has been fabricated, configurations such as those shown at Fig #1 can trap air in the SYSTEM.

Fig #1

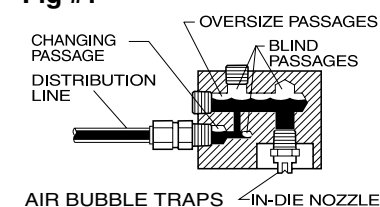
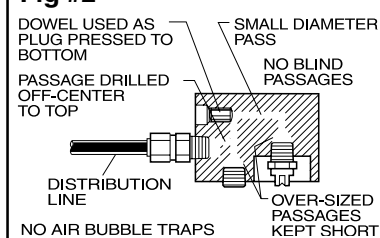

Fig #2 shows the same SYSTEM without the potential problems of the one above it.

Fig #2



NOTE: We recommend you contact L.S.P. or our representative for suggestions before attempting to fabricate any part of the DISTRIBUTION SYSTEM, or use INDIE NOZZLES.

ACCESSORIES

A. Nozzle Assemblies

There must be at least one of these items for each EJECTOR on the UNIT.

1. P20X SPRAYNOZZLE

Consists of a Nozzle Tip and a Check to prevent after-drip.

2. P-21X FLEXTUBE

Consist of a SPRAYNOZZLE on a StaPut Flexible Tube.

3. P-22X MAGNATUBE

Consists of a FLEXTUBE mounted on a MAGNABASE.

4. P-24X INDIE NOZZLE

Consists of only the Nozzle Tip with a built-in check.

5. P-25X NPT NOZZLE

Consists of a SPRAYNOZZLE with male 1/8 NPT Thread connection.

Type of Spray Tip	SPRAYNOZ Number	FLEXTUBE Number	MAGTUBE Number	NPT Number	INDIE NOZ Number
110° Fan Spray	P-201	P-211	P-221	P-251	P-241
80° Fan Spray	P-202	P-212	P-222	P-252	P-242
65° Fan Spray	P-203	P-213	P-223	P-253	P-243
25° Fan Spray	P-205	P-215	P-225	P-255	P-245
55° Cone Spray	P-207	P-217	P-227	P-257	N/A
Rt. Angle Spray	P-209	N/A	N/A	P-259	N/A

B. P-940 HYPRESSURE NYLON TUBING

For use as flexible DISTRIBUTION LINE. L.S.P. supplies this tubing because it is the only type of flexible LINE found to give satisfactory performance. No other type works well enough.

C. P-925 NOZZLE BRACKET

Used to support SPRAYNOZZLES. Gives complete control of aiming the spray pattern. Moves up/down 5", rotates 360°, and tilts 180°. Adapts to the MAGNABASES.

D. P-903 COVER PLATE

Used to replace an EJECTOR when necessary. Acts as a seal-plate. Allows continued operation while EJECTOR is removed.

4. Trapped Air

The examples in Figs #1, 2, and 3 below, show how "pockets" can trap air in the SYSTEM. They do not show every possible situation, but give an idea of what to look for.

Example #2:

A high area in the DISTRIBUTION LINE can keep an air bubble from being ejected. See Fig.#3.

To cure the problem, Try cycling the UNIT as fast as possible at full volume to drive the bubble up to the NOZZLE.

If the above doesn't work, modify the LINE so travel is always "up" (hold the high area of the LINE down, or lift the NOZZLE higher while cycling the UNIT).

Fig #3

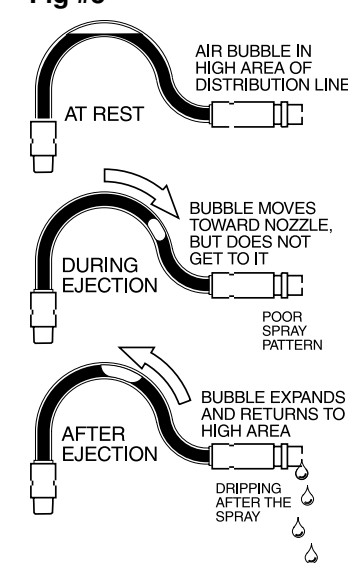

The following ACCESSORIES are available to enhance the performance of your SYSTEM. See L.S.P.'s Catalog for more details.

E. P902 Replacement Ejector

Is a direct replacement for any EJECTOR. Used as a spare to replace an EJECTOR should one go down.

F. ACTUATORS

Any ACTUATOR listed below may be used to operate the UNIT.

1. E-300 PresSpray Controller

Provides delay time, counter, and pulsator functions. Along with many others to give complete control of the UNIT's applicator.

2. E-305 Pulsator Actuator

Provides a pulsator function for multiple ejections each cycle.

3. E-310 Counter Actuator

Provides a counter function to eject after a set number of cycles.

4. E-315 Timer Actuator

Provides a controllable cycle timer for independent cycling.

5. P-912 Solenoid Actuator

Consists of a solenoid operated air valve for use as an Actuator.

6. P-908 AirTimer Actuator

Consists of an air operated cycling timer for use as an Actuator.

7. P-901 Mechanical Actuator

Consists of a mechanically tripped valve for use as an Actuator.

G. MAGNABASES

Holds the NOZZLE BRACKET, MECHANICAL ACTUATOR, and other ACCESSORIES for easy positioning and adjustment.

1. P-905 MAGNABASE

Holds with a force of 100 pounds.

2. B-909 MAGNABASE

Holds with a force of 200 pounds.

REPLACEMENT PARTS LISTINGS

Figure #4

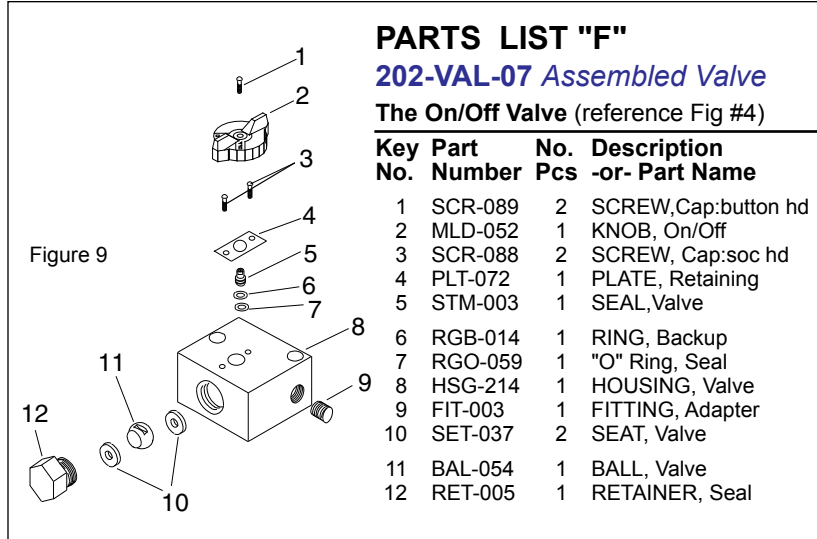
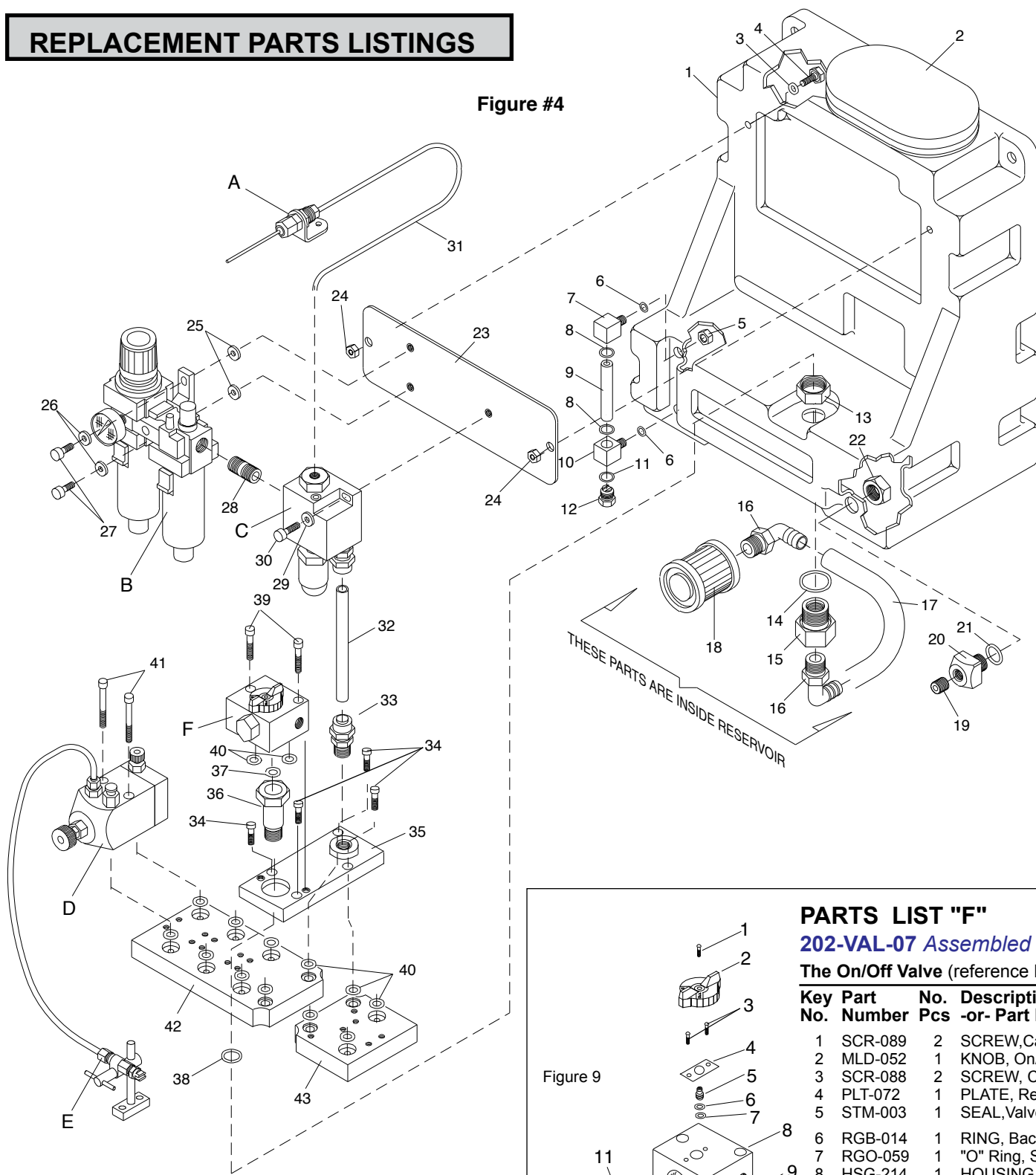

Figure 9

PARTS LIST "F" 202-VAL-07 Assembled Valve The On/Off Valve (reference Fig #4)

Key Part No.	No. Number	No. Pcs	Description -or- Part Name
1	SCR-089	2	SCREW,Cap:button hd
2	MLD-052	1	KNOB, On/Off
3	SCR-088	2	SCREW, Cap:soc hd
4	PLT-072	1	PLATE, Retaining
5	STM-003	1	SEAL,Valve
6	RGB-014	1	RING, Backup
7	RGO-059	1	"O" Ring, Seal
8	HSG-214	1	HOUSING, Valve
9	FIT-003	1	FITTING, Adapter
10	SET-037	2	SEAT, Valve
11	BAL-054	1	BALL, Valve
12	RET-005	1	RETAINER, Seal

Supplemental Parts Listings

The Parts below are further broken down in Supplemental Parts Listings and Illustrations.

Key	Description	References
A	ACTUATOR	See Parts Listing with Actuator used
B	AIR HANDLING	Refer to Parts List "B" & Fig. #5
C	UNI VALVE	Refer to Parts List "C" & Fig. #6
D	EJECTOR	Refer to Parts List "D" & Fig. #7
E	NOZZLE ASSY	Refer to Parts List "E" & Fig. #8
F	On/Off Valve	Refer to Parts List "F" & Fig. #9

PARTS LIST "C"

MAIN PARTS LIST PresSpray II (reference Fig #4)

The Following are Common to All Models

Key Part No.	No. Number	No. Pcs	Description -or- Part Name
1	RES-032	1	RESERVOIR, Fluid:
2	COV-019	1	COVER, Reservoir:
3	RGO-017	2	"O" RING, Seal:
4	BRK-026	2	BRACKET, Mounting:
5	NUT-058	2	NUT, Hexagon: jam
6	RGO-030	2	"O" RING, Seal:
7	INL-026	1	INLET, Sight Glass:
8	RGO-013	2	"O" Ring, Seal:
9	PIP-008	1	PIPE, Sight glass:
10	OUT-009	1	OUTLET, Sight Glass:
11	RGO-034	1	"O" RING, Seal:
12	PLG-026	1	PLUG, Sight glass:
13	NUT-161	1	NUT, Jam: special
14	RGO-056	1	"O" RING, Seal:
15	ADP-048	1	ADAPTER, Bulkhead:
16	FIT-057	2	FITTING, Elbow: barbed
17	TUB-160	1	TUBE, Fluid:
18	FIL-018	1	FILTER, Fluid:
19	FIT-062	1	FITTING, Plug: pipe
20	OUT-010	1	OUTLET, Drain:
21	RGO-051	1	"O" RING, Seal:
22	NUT-062	1	NUT, Hexagon: jam
23	PLT-063	1	PLATE, Mounting:
24	NUT-104	2	NUT, Locking: jam
25	SPC-019	2	SPACER, Mounting:
26	WAS-015	2	WASHER, Plain:
27	SCR-028	2	SCREW, Cap: soc hd
28	FIT-063	1	FITTING, Nipple:
29	WAS-002	1	WASHER, Lock:
30	SCR-008	1	SCREW, Cap: soc hd
31	TUB-019	1	TUBE, Actuator:
32	TUB-218	1	TUBE, Air line:
33	FIT-025	1	FITTING, Adapter: tube
34	SCR-066	4	SCREW, Cap: soc hd
35	202MAN01	1	MANIFOLD, Air:
36	INL-044	1	INLET, FLuid
37	RGO-040	1	"O"Ring, seal
38	RGO-012	1	"O"Ring,seal
39	SCR064	2	SCREW, Cap:soc hd

The Following is Common to Model P-152 (Units with 2 Ejectors)

Key Part No.	No. Number	No. Pcs	Description -or- Part Name
"D"	202-EJT-01	2	EJECTOR, Lubricant:
40	RGO-032	10	"O" RING, Seal:
41	SCR-036	4	SCREW, Cap: soc hd
42	MAN-011	1	MANIFOLD, Mounting:
43	MAN-011	1	MANIFOLD, Mounting:

The Following is Common to Model P-154 (Units with 4 Ejectors)

Key Part No.	No. Number	No. Pcs	Description -or- Part Name
"D"	202-EJT-01	4	EJECTOR, Lubricant:
40	RGO-032	14	"O" RING, Seal:
41	SCR-036	8	SCREW, Cap: soc hd
42	MAN-013	1	MANIFOLD, Mounting:
43	MAN-011	1	MANIFOLD, Mounting:

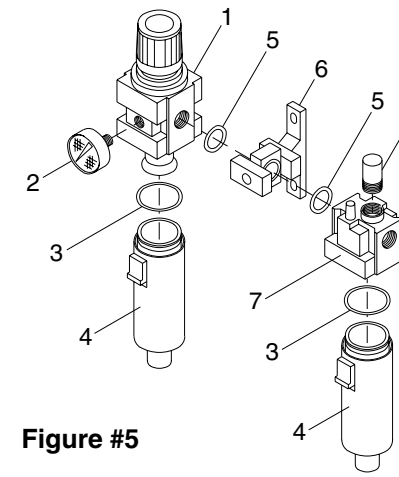

Figure #5

PART LIST "B" Air Handling (reference Fig #5)

REG-016 Includes all except GAU-001

Key Part No.	No. Number	No. Pcs	Description -or- Part Name
1	ACY-028	1	REGULATOR, Bonnet:
2	GAU-001	1	GAUGE, Pressure:
3	RGO-074	2	"O" RING, Seal:
4	ACY-026	2	BOWL, Filter/Oiler:
5	RGO-067	2	"O" RING, Seal:
6	ACY-030	1	BRACKET, Filter/Oiler:
7	ACY-029	1	OILER, Bonnet:
8	ACY-022	1	DOMES, Sight:

Inspecting a UNI VALVE

Refer to PARTS LIST "C" for Key No's shown in parenthesis.

- Remove the AIR SUPPLY**
Turn off the AIR SUPPLY to the UNIT.
- Disconnect the ACTUATOR TUBE**
Unlock Tube by pushing down on the collar around it where it enters Fitting(#10). While this collar is held down, the Tube can be pulled from the Fitting.
- Dis-assemble the UNI VALVE**
 - Remove Cylinder(#9) from on top of the UniValve.
 - Remove Muffler(#12) from bottom of the UniValve.
 - Insert a small tool up into the hole the Muffler came from and push Spool(#7) out the top of the UNI VALVE. Be careful, don't get too rough doing this.
- Inspect the Parts**
 - Remove the "O"Rings (#4,5,6) from the Spool (#7).
 - Clean and inspect all parts and seals. Replace broken or deformed parts, and worn, cut, or nicked seals.
 - With no "O"Rings on it, the Spool (#7) should move freely in the Valve Housing (#1) with no sticking or forcing. If not, check for deformation of the Spool or of the seats in the Housing.
 - Inspect the tiny (.031 Dia.) hole located at the bottom of the counter-bore in the end of the Spool. It must be through (to the hole in the side of the Spool) and unobstructed for the UNI VALVE to function properly.

Figure #6

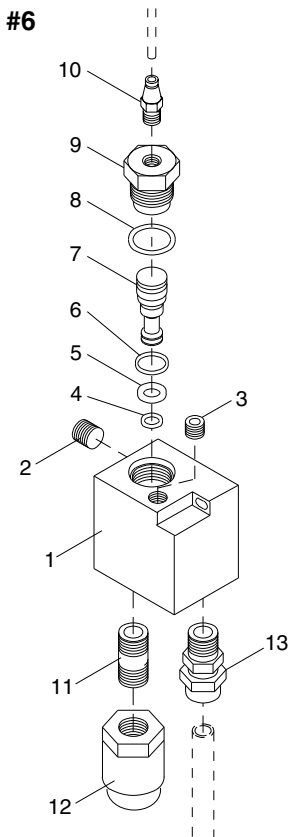

PARTS LIST "C"

The UniValve (reference Fig #6)

202-VAL-05 Assembled Valve

Key Part No.	No. Number	No. Pcs	Description -or- Part Name
1	202-HAS-01	1	HOUSING, Valve
2	FIT-058	1	FITTING, Plug
3	FIT-003	1	FITTING, Plug
*4	RGO-059	1	"O" RING, Seal
*5	RGO-065	1	"O" RING, Seal
*6	RGO-069	1	"O" RING, Seal
7	SPL-024	1	SPOOL, Valve
*8	RGO-066	1	"O" RING, Seal
9	CYL-037	1	CYLINDER, Valve
10	FIT-020	1	FITTING, Adapter
11	FIT-045	1	FITTING, Nipple:
12	MUF-002	1	MUFFLER, Exhaust
13	FIT-025	1	FITTING, Adapter

* REPAIR KIT 202-ACY-07