

# INSTALLATION, OPERATION, and TROUBLESHOOTING with

## REPLACEMENT PARTS LISTING for the BlastMatic B-524 and B-550



P.O. Box 5303, 61125  
 2511-20TH ST., 61104 ● ROCKFORD, IL  
 TEL: 815-226-8090 ● FAX: 815-226-9250  
 E-MAIL: SALES@LSPIND.COM

Consists of a **UniVALVE** (air valve) and a **TUBE & NOZZLE** (blow-off tube) combined into a single Unit. On/off control is supplied by an **ACTUATOR**. **Fig. #1** illustrates the various options to a **BlastMatic** set-up. Use **Fig. #1** along with the descriptions below for instruction.

- UniVALVE**...an oversized air valve. Opens to turn air on, closes to turn it off. Is controlled by the **ACTUATOR** at the **RELIEF PORT**.
- INLET PORT**...where the **OPERATING AIR** is connected to the **UNIT**
- RELIEF PORT**...where **ACTUATOR** or **ACTUATOR TUBE** connects
- TUBE & NOZZLE**...the blow-off tube. Has a special nozzle at the end to focus the air stream.
- ACTUATOR**...Supplies the method by which the **BlastMatic** will be triggered. The most used methods are described below.
  - Mechanical**...uses motion of press to trigger the **Unit**. Trips by having a moving member deflect the wand. **Model No. P-901**
  - Solenoid**...uses 110Vac electricity to trigger the **Unit**. You Supply the switch or controller to handle the cycling. **Model No. P-912**
  - BlastMatic Controller**...offers electronic control of **Unit**. Trips by magnetic pick-up. Allows setting delay and blow-off time. Supplies 12Vdc to a Solenoid Valve to trigger **UNIT**. **Model No. B-300**
- ACTUATOR TUBING**...allows locating the **ACTUATOR** a distance from the **UNIT** when this is necessary. Keep this **TUBE** as short as practical for best performance.
- AIR LINE, FITTINGS, etc.**...brings the **AIR SUPPLY** to the **UNIT**. A **SHUT-OFF VALVE** may be used on this **LINE** for convenience. The **LINE, FITTINGS** (and **SHUT OFF VALVE**, if used) must have an I.D. of sufficient size to insure proper air passage.
- MAGNETIC BASES**...afford easy location and re-positioning of the **UNIT**. 100 pounds of holding force is available with **Model No. P-905 MagnaBase**. 200 pounds with **Model No. B-909**.

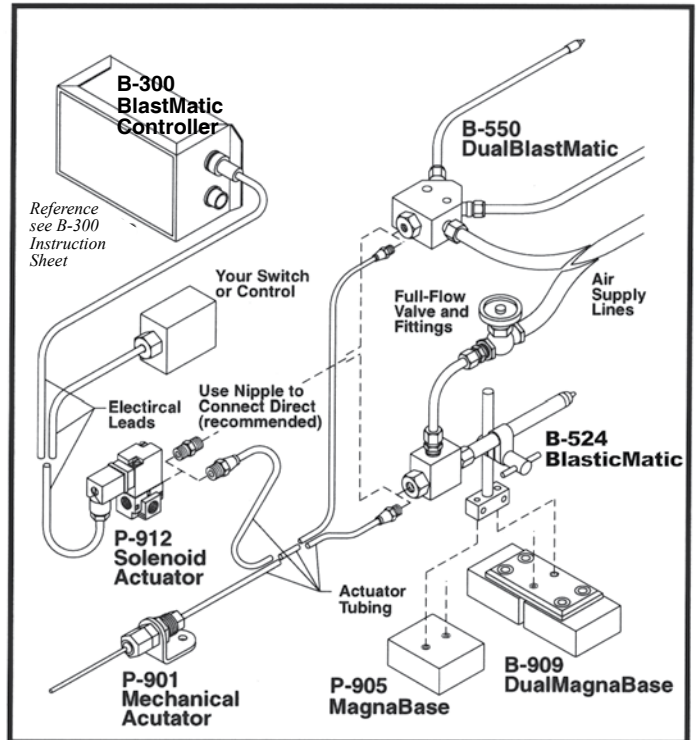

## INSTALLATION INSTRUCTIONS

### A) Locating the BlastMatic

Position the **BlastMatic** to blow the parts out of the press.

### B) Mounting the BlastMatic

Mount the **BlastMatic** by one of the following methods.

- a) Permanent setup; bolt **Unit** directly to bed of press.
- b) Easy setup and removal; use **P-905** or **B-909 MagnaBase**.

### C) Installing the Operating Air Supply

Install an **AIRLINE** from an **AIR SUPPLY** to the **INLET PORT** on the side of the **UniVALVE**. For greatest efficiency do as follows:

- a) Use the highest Air Pressure available. Must be at least 50 P.S.I.
- b) **DO NOT** retard the Air Flow. Watch out for the following.
  - ...**DON'T** use under-sized **AIRLINE** (See chart below for sizing).
  - ...**DON'T** kink, crimp, or put sharp bends in this **AIRLINE**.
  - ...**DON'T** attach **AIRLINE** with an elbow or reducing fitting.
  - ...**DON'T** use minimum passage **AIRLINE** over long distances.

For convenience, any sort of **SHUT OFF VALVE** may be installed on this **AirLine**, *but...it must be large enough.*

MINIMUM PASSAGES for AIRLINE, FITTINGS, and SHUT OFF VALVE	Type of Unit	Passage Inside Dia	Pipe Size Schedule 40
	BlastMatic	.200 Inch	1/4 NPT
	DualBlastMatic	.325 Inch	3/8 NPT

### D) Installing the Actuator

You must have an **ACTUATOR** to operate the **BlastMatic**. If you have none, one must be obtained. As seen in **Fig.1**, there are a variety to choose from. Contact **L.S.P. Industries**, or our representative, if you require help in making a selection.

Install the **ACTUATOR** per the **INSTRUCTIONS** supplied with it.

For best response, the **ACTUATOR** should be located as close to the **BlastMatic** as practical. If **ACTUATOR TUBING** is used, keep it as short as possible.

## OPERATING INSTRUCTIONS

### A) Supply the Operating Air

Connect the **AIR SUPPLY** to the **BlastMatic**. If the **AIR SUPPLY** has a **SHUT OFF VALVE**, insure this valve is fully opened.

### B) Activating the BlastMatic

Trigger the **ACTUATOR** to operate the **BlastMatic**. All **ACTUATORS** perform the same end function, they exhaust air from the **RELIEF PORT** of the **UniVALVE** on the **BlastMatic**. When this **PORT** is vented to atmosphere, the **Unit** is activated.

### C) Deactivating the BlastMatic

As venting the **RELIEF PORT** of the **UniVALVE** activates the **BlastMatic**; closing this same **PORT** deactivates the **UNIT**.

## REPLACEMENT PARTS LISTING

Use the appropriate Replacement Parts Listing below depending on the type of **BlasticMatic** you are using.

### Parts Listing for the BlastMatic Nozzle Assembly

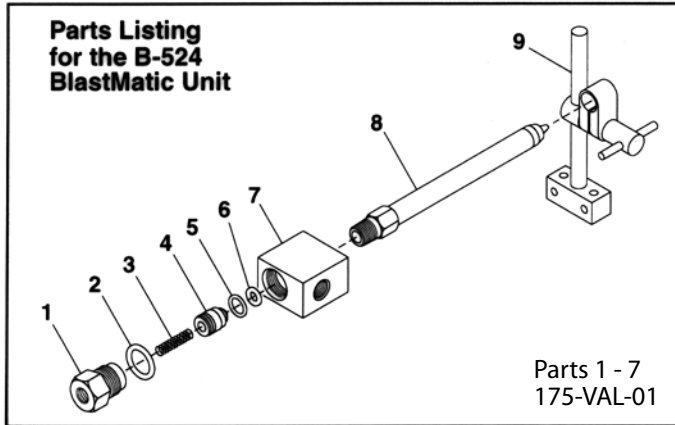

Key	Part No.	Description
1	CYL035	CYLINDER, Valve:
2	RGO012	O-RING, Seal:
3	SPG023	SPRING, Compression:
4	SPL022	SPOOL, Valve:
5	RGO014	O-RING, Seal:
6	RGO050	O-RING, Seal:
7	HSG063	HOUSING, Valve:
8	175TAN01	TUBE & NOZZLE ASSY:
9	290BRK02	BRACKET ASSEMBLY:

### Parts Listing for the DualBlastMatic Assembly

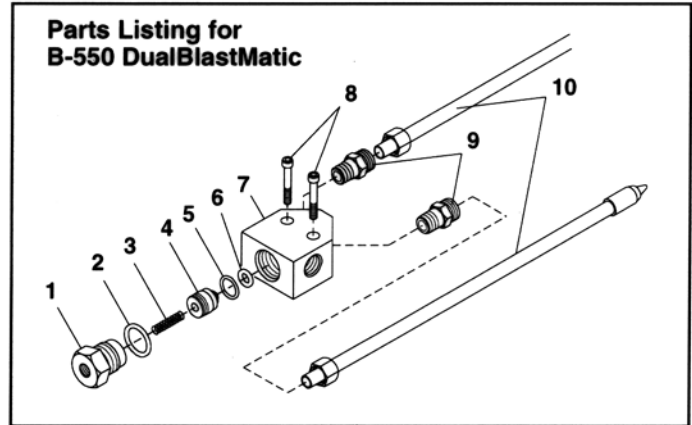

Key	Part No.	Description
1	CYL036	CYLINDER, Valve:
2	RGO058	O-RING, Seal:
3	SPG023	SPRING, Compression:
4	SPL023	SPOOL, Valve:
5	RGO035	O-RING, Seal:
6	RGO059	O-RING, Seal:
7	HSG064	HOUSING, Valve:
8	SCR041	SCREW, Cap:soc hd
9	FIT061	FITTING, Adapter:
10	173TAN02	TUBE & NOZZLE ASSY:

## TROUBLESHOOTING

PROBLEMS	SOLUTIONS
<b>I. Unit does not cycle when Actuator is activated.</b>	<p>A) Check the air pressure of the Air Supply ( must be at least 50 PSI).</p> <p>B) Check if there is sufficient Air Supply. The Air Supply Line may be kinked or clogged or otherwise restricted</p> <p>C. If using Actuator Tubing, check it for leakage (cut or worn thru) and/or blockage (kinked or clogged). Also check it's connections for leakage or blockage.</p> <p>D) Check if the Actuator is the problem as follows:</p> <ol style="list-style-type: none"> <li>1) Disconnect the Actuator from the Blastmatic Unit; or if using Actuating Tubing, from the end of this tubing.</li> <li>2) A relatively small amount of air should flow from this port, and the BlastMatic Unit should turn "ON".</li> <li>3) Put something over this port to stop the air flowing. When this is done, the BlastMatic Unit should turn "OFF". If the Unit functions this way the problem is with the Actuator; see TROUBLESHOOTING for the Actuator being used.</li> </ol> <p>If the Unit does not Function this way the problem is in the UniValve. See problem II below.</p>
<b>II. UniValve does not seem to be functioning properly.</b>	<p>A) Turn off Air to the Unit. Remove CYLINDER (#1) from the HOUSING (#7) and check the following:</p> <ol style="list-style-type: none"> <li>1) Check inside CYLINDER (#1) for wear or contamination. Clean or replace as needed.</li> <li>2) Check outside of SPOOL (#4) for wear or contamination. Clean or replace as needed.</li> <li>3) Check SPRING (#3). Replace if broken or deformed.</li> <li>4) Check both O-RINGS's (#2 &amp; #5). Replace if worn or cut.</li> </ol>
<b>III. UniValve does not shut "OFF" immediately when Actuator is deactivated.</b>	<p>A) Check Air Pressure, Air Line, and Actuator per Problem I above, see Solution A &amp; B.</p> <p>B) Check SPRING (#3) in UniValve. Replace if broken or deformed.</p> <p>C) Check if the Actuator is shutting off entirely. There should be no air leaking from it when "OFF".</p>
<b>IV. Unit has less power than when initially installed.</b>	<p>A) Nozzle at the end of Blow-Off Tube has an insert in it. If the Air Supply is not filtered, the areas around this insert can become clogged. Remove this Tube and blow air backwards thru the Nozzle to unclog. Replace if impossible to clean.</p> <p>B) Check if initial set-up has changed. Examples: Air Pressure has been set lower; Air Line was replaced and Line or fittings with improper passage was used; original Air Line has deteriorated and has collapsed or become clogged.</p>