

TROUBLE SHOOTING

PROBLEMS	POSSIBLE CAUSES	SOLUTIONS
Pump will not start, stalls.	1. Inadequate air supply 2. Contaminated air supply. 3. Ruptured Diaphragm 4. Check Shuttle Valve for wear.	1. Increase air inlet pressure. 2. An air dryer might be required. 3. Replace diaphragms (2) 4. Replace slide valve if necessary. #3A
Pump operates but no fluid.	1. A leak or break in the inlet line. 2. A leak or break in the discharge line,	1. Replace line 2. Replace line.
Pump leaks through exhaust port.	1. Leak at exhaust port. O-ring. 2. Shaft Seal O-ring worn or damaged. 3. Inadequate slide lubrication	1. Replace Exhaust Port. # 7 2. Replace Shaft Seal O-ring. 3. Replace with Shuttle Valve Kit
Flow rate is low.	1. Tubing or hose is damaged or blocked 2. Heavy viscosity 3. Valves may not be seating properly.	1. Clean or replace. 2. Increase air pressure. Reduces solution viscosity/ 3. Reinstall Check Valves.
Pump leaks	1. Ruptured or worn out Diaphragms. 2. Pump housing screws not torqued adepty.	1. Replace Diaphragms. 2. Toque to 20 inch pounds.

INSTALLATION, OPERATION, and TROUBLESHOOTING

with REPLACEMENT PARTS LISTING for
TransferPump Model No. FC-7310



P.O. Box 5303, 61125
2511-20TH ST., 61104 • ROCKFORD, IL
TEL: 815-226-8090 • FAX: 815-226-9250
E-MAIL: SALES@LSPIND.COM

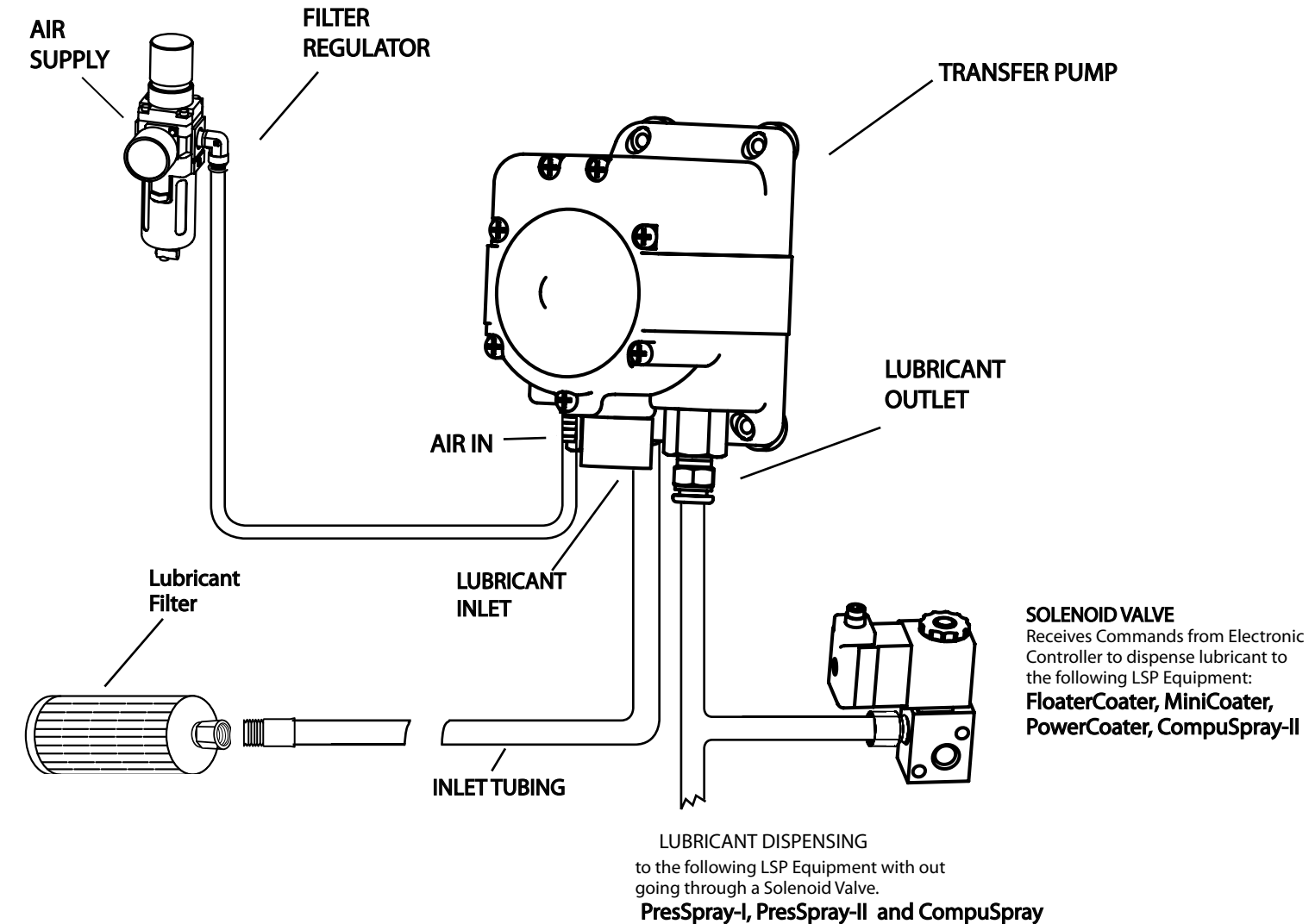

PRODUCT DATA

Product Description	Double Diaphragm Pump.
Wetted Parts, Viton	Diaphragm Check Valve Seat.
Housing & Check Valve Material	Glass Reinforced Polypropylene
Springs	Stainless Steel

CHEMICAL SPECIFICATIONS

Recommended for:
Oils, Solvents, d-Limonene, Aromatic & Halogenated Hydrocarbons, Acids.
Not Recommended For:
Ketones, Acetones, Automotive Brake Fluid, Ammonia, Ethanol.

CHEMICAL COMPATIBILITY

Air Pressure	20 to 60 PSI PRESSURES ABOVE 60 PSI WILL BE DETRIMENTAL TO THE LIFE OF THE PUMP.
Flow Rates	Max Up to 5 GPM
Priming	Dry 10 ft. Wet 15 ft.

MOUNTING

The LSP Industries FC-7310 self priming Pump should be mounted in a dry and adequately ventilated area. This Pump can be mounted several feet from the Tank, above or below the liquid level. For most applications, no more than 5 feet above the fluid level is recommended.

This is not a submersible pump.

Secure Pump to desired fixture with #10 UNF screws through rubber grommets in the feet of the Pump.

Ports Must Be Facing Down.

HOSE CONNECTIONS

All Fittings, Solution Inlet, Solution Outlet and Air IN are inserted in the Housing using a quick change feature. This allows the removal of the fittings so the tubing can be attached to the fittings and then reinserted in the housing and then snapping the Quick Change Locking Mechanism in place.

Solution Inlet 1/2" Push/Pull Fitting Polypropylene Tubing

Solution Outlet 3/8" Push/Pull /Fitting Polypropylene Tubing

Air In 3/8" Barb Fitting Polypropylene Tubing

PLUMBING

All Hose should be flexible to avoid stress on pump parts. DO NOT crimp or kink hose. All Hose should be the same size as the port fittings.

The use of Check Valves in the plumbing system could interfere with the priming ability of the Pump. Check valves in the pumping system must have a cracking pressure of 2 PSI maximum.

The FC-7310 Pump comes with a 100 Micron Filter, fine enough to keep out large foreign objects and 5' of Polypropylene Inlet Tubing.

OPERATION

It is strongly recommended that a Regulator and Gauge be installed in the airline prior to the FC-7310.

At start-up, regulate air pressure to desired PSI, the heavier the

viscosity the higher the eventual PSI. For most installations 20 PSI is a minimum starting point. Flow and pressure can be adjusted by increasing or decreasing gas pressure to accommodate varying product viscosities, length of lines or other installation conditions. High viscosity fluids and hose length will limit priming distance.

AIR SUPPLY MUST BE DRY AND OIL FREE

Compressors must have dryers and/or a water separator on the distribution system. Pumps that fail due to water in the air chamber will not be covered under the limited warranty.

GENERAL SAFETY INFORMATION

Protect yourself and others by observing all safety information. Follow the safety codes and Occupational Safety and Health Act (OSHA).

WARNING

DO NOT PUMP GASOLINE OR FLAMMABLE LIQUIDS OR USE WHERE FLAMMABLE VAPORS ARE PRESENT

Do Not Power with CO₂ or N₂

CAUTION:

Do not clean or service the Pump, hoses or valves while the system is pressurized. Remove the airline to depressurize the Pump and have towels available to clean up the residue.

PREVENTIVE MAINTENANCE TIPS

Tips to Help Prolong the Pump Life.

If outside, before freezing drain pump.

Air must be dry. (no condensate from the compressor.)

CAUTION:

Do not exceed 100 PSI, (6.9) Air Pressure.

CONTINUOUS OPERATION AT 120F (48.9C) WILL REDUCE PUMP LIFE.

DISASSEMBLY PROCEDURE

Remove all Air Lines and IN/OUT Solution Lines

Using a flat bladed screw driver slide Retaining Clips, (7), away from the Fittings.

Pull down on Tubes and fittings will be extracted from the FC-1034 Pump.

Remove Muffler from the Pump.

Again using the flat bladed screw driver, slide Retaining Clips, (7), away from the Muffler.

Pull Muffler down and out of the FC-1034 Pump.

Remove the 7 screws from the Front Cap and the 7 screws from the End Cap

With the Front Cap facing up place a flat screw driver into the slot located above the Muffler Port and just below the pad marked **Air/CO₂** and lift off the Front Cap.

Remove the rear End Cap by placing the flat bladed screw driver under the fully opened Port Retaining Clip and lifting off.

NOTE the position of the Suction and Discharge valves before removing them. The first Diaphragm is removed from the Pump Shaft by unscrewing in a counter clockwise direction. The second Diaphragm is removed by placing the flat tip of a screwdriver into the exposed slot at the end of the Pump Shaft and unscrewing the Diaphragm from the Shaft. To remove the Flange Housing, place the flat screw driver into the Air Bleed Hole on the lower side of the Flange Housing and lift up the lower end separating the Flange Housing from the Pump body.

The Slide Valve Assembly and Pump Shaft can be removed by simply pulling them from the Pump Body. The Pump Shaft then can be removed from the Slide Valve Yoke Assembly.

REASSEMBLY PROCEDURE

Assemble the Slide Valve and Pump Shaft with the Yolk placed between the two, (2), Bumpers on the Pump Shaft. Install the Slide Valve/Pump Shaft assembly into the Pump Body, making sure the O-Rings in the Slide Valve are in place.. To install the Flange Housing pre-lube the O-Ring with Parker Super "O" lube and install on the Flange Housing and place the housing over the Pump Body aligning the flange housing with the Pump Body ribs pressing it into place.

Install the first Diaphragm and O-Ring on to the Pump Shaft using a flat blade screw driver to hold the Pump Shaft until the Diaphragm is tight.

Install the second Diaphragm and O-Ring on to the Pump Shaft turning clockwise until tight.

Install the Suction Valves with Springs facing into the Pump Body and the Discharge Valves with the Springs facing out. See Arrows on Pumps rear End Cap below Suction and Discharge Ports.

Install the Port Retainer Clips (large), into the Pump and End Cap (mounting base), and install the seven (7) screws into Pump Body and turn until snug and then torque to 22 - 24 inch pounds, Install Port Retaining Clips (small) into the Pump Body, Tabs facing out, position the front Front Cap and install the seven, (7) screws into the Pump Body and tighten until snug and then torque to 22 - 24 inch pounds.

Install the Muffler in the Center Port by pushing it in and sliding the Retainer Clip into place. Install the Suction and Discharge Ports and the (Air In) Port fitting and slide the Retainer Clips in place.

Check for leaks.

REPLACEMENT PARTS LIST for TransferPump FC-7310

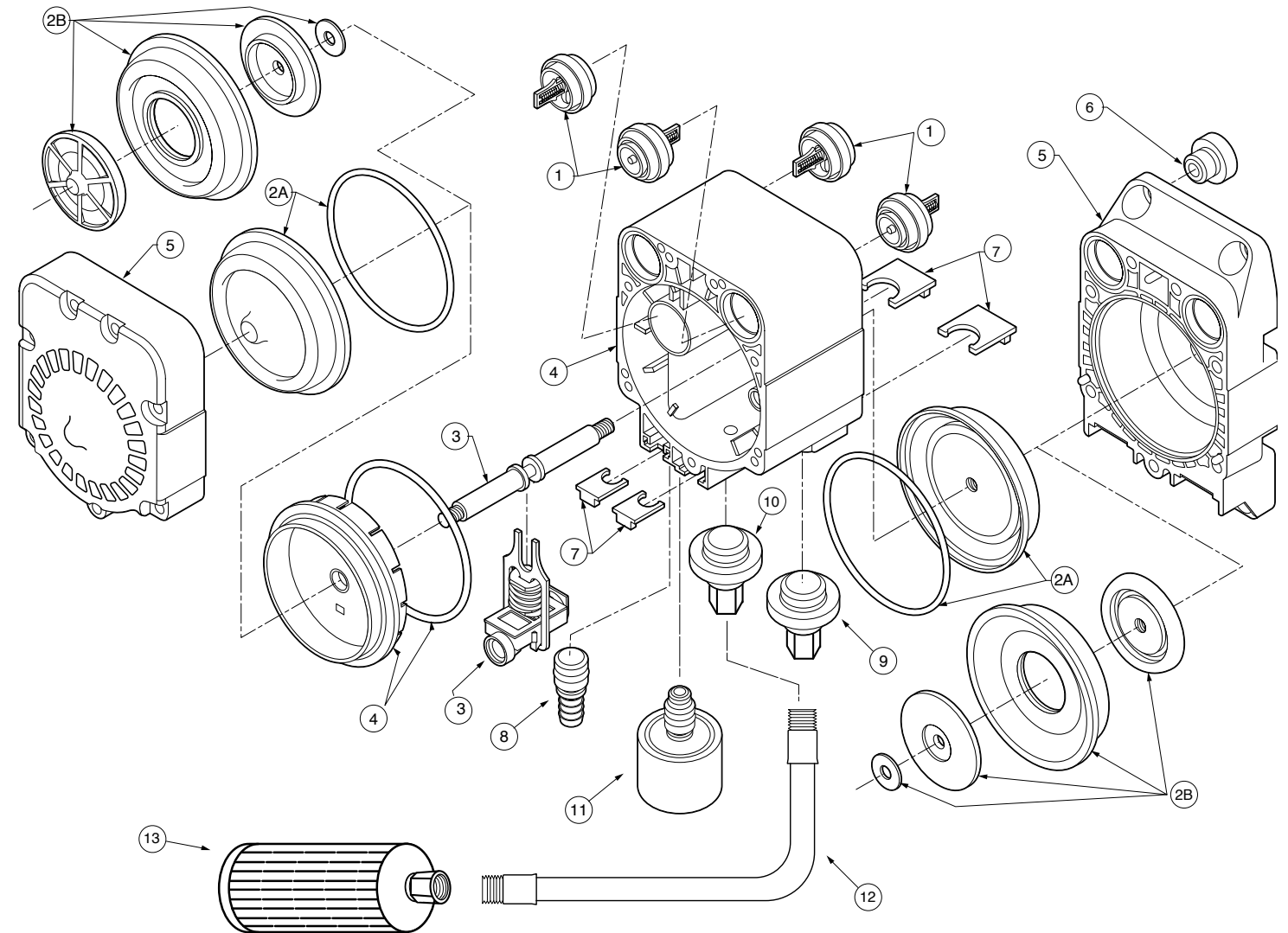

KEY	PART NO.	DESCRIPTION	QTY	KEY	PART NO.	DESCRIPTION	QTY
1	ACY-038	KIT, Ck Valve Assy, Viton*, Hastalloy	4			Retainer Clips, Small	2
2A	20730-006A	KIT, Diaphragm, Santo* w/O"-Ring	2			Retainer Clips, Large	2
2B	ACY-039	KIT Diaphragm, Viton*	2			Exhaust Port	1
3	20751-002A	KIT, Shaft & Slide Valve Assy, Viton*	2			Muffler	2
4	20896-000A	KIT, Flange & Housing Assy. w/O"-Ring	2	8	01510-000	FITTING, Air Inlet, 3/8 Barb	1
5	20753-000A	KIT, End Caps	2	9	420-OUT01	FITTING, Solution outlet 1/4 NPTF	1
6	20132-000	KIT, Grommets	2	10	ADP072	FITTING, Solution Inlet, 1/4 NPTF	1
7	20793-100A	KIT, Hardware - includes		12	TUB-100	TUBING, Solution Inlet: 3/8 NPTM x 1 NPTM	1
		Screws #10 X 1.5 Hi-Low (Not shown)	14	13	FIL-019	FILTER, Solution	