

TROUBLESHOOTING INSTRUCTIONS

PROBLEM	SOLUTION
<p>V. All or part of the Unit must be taken apart to check out a problem above.</p> <p>Carefully follow the instructions given at the right to insure proper disassembly and assembly. Improper handling may cause damage to the Unit.</p>  <p>To disassemble always start here!</p>	<p>A. FlexTube Assembly (#1 to #6 on Parts List).</p> <ol style="list-style-type: none"> Removing the FlexTube. <ol style="list-style-type: none"> Unscrew the FlexTube from the HOUSING (#10 or #11 on Parts List) by torquing at the fitting noted in the illustration at the left. DO NOT unscrew any other fitting on the FlexTube until it has first been taken off the HOUSING or irreparable damage can be caused. After removing the FlexTube check for SPACER (#5 on Parts List) and SLEEVE (#6 on Parts List). These items may be lodged in the HOUSING; if so, remove them. Checking FlexTube for Blockage. <ol style="list-style-type: none"> Blow into the copper tube sticking out the end of the FlexTube. If air passes through, it indicates the air passage is clear. Block the end of the copper tube with thumb. Blow into the Nozzle. If air passes through, it indicates the coolant passage is clear. If either passage is blocked, back flushing with a high-pressure stream of air into the Nozzle should dislodge any contamination. Checking FlexTube for Damage. <ol style="list-style-type: none"> Unscrew the TUBE & HSG ASSY (#3 on Parts List) from the FlexTube. Check that the end of the copper tube is not deformed. Check the copper tube to see if it is tightly joined to the square insert in the housing. Check around the square insert for lodged contamination. Check that the point on the square insert is not deformed. Clean or replace TUBE & HSG ASSY as necessary. Check the TUBE (#4 on Parts List), replace if cut through to inside. Check SPACER (#5 on Parts List), replace if deformed. Check SLEEVE (#6 on Parts List), replace if cut or badly deformed. Installing the FlexTube. <ol style="list-style-type: none"> Assemble in reverse of disassembly. Make sure there is no SPACER or SLEEVE lodged in the HOUSING before inserting the FlexTube. Screw FlexTube into the HOUSING until hand tight. Then continue torquing for 1-1/2 to 2 more turns. The FlexTube must be torqued deep enough into HOUSING that the SLEEVE seals the joint. <p>B. Air Control Valve (#7 & #8 on Parts List).</p> <ol style="list-style-type: none"> Checking the Air Control Valve. <ol style="list-style-type: none"> Check that the tip of the Valve is not deformed. Check "O" RING (#8 on Parts List), replace if bad. Check that the Valve Seat in HOUSING (#10 or #12 on Parts List) is not deformed, and that all the passages are clear. Installing the Air Control Valve. <ol style="list-style-type: none"> Unscrew the Valve so that its tip is drawn up into the assembly as far as it will go. Screw VALVE ASSY back into HOUSING until bottoms.

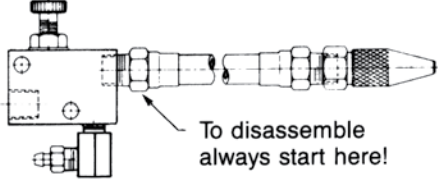

P.O. BOX 5303, 61135
 3611-20TH ST., 61104 • ROCKFORD, IL
 TEL: 815-226-8090 • FAX: 815-226-9360
 E-MAIL: SALES@LSPIND.COM

INSTALLATION, OPERATION, and TROUBLESHOOTING INSTRUCTIONS with REPLACEMENT PARTS LISTINGS for the BasicMist Models M-020, M-022 & M-023 MagnaMist Models M-122, & M-123

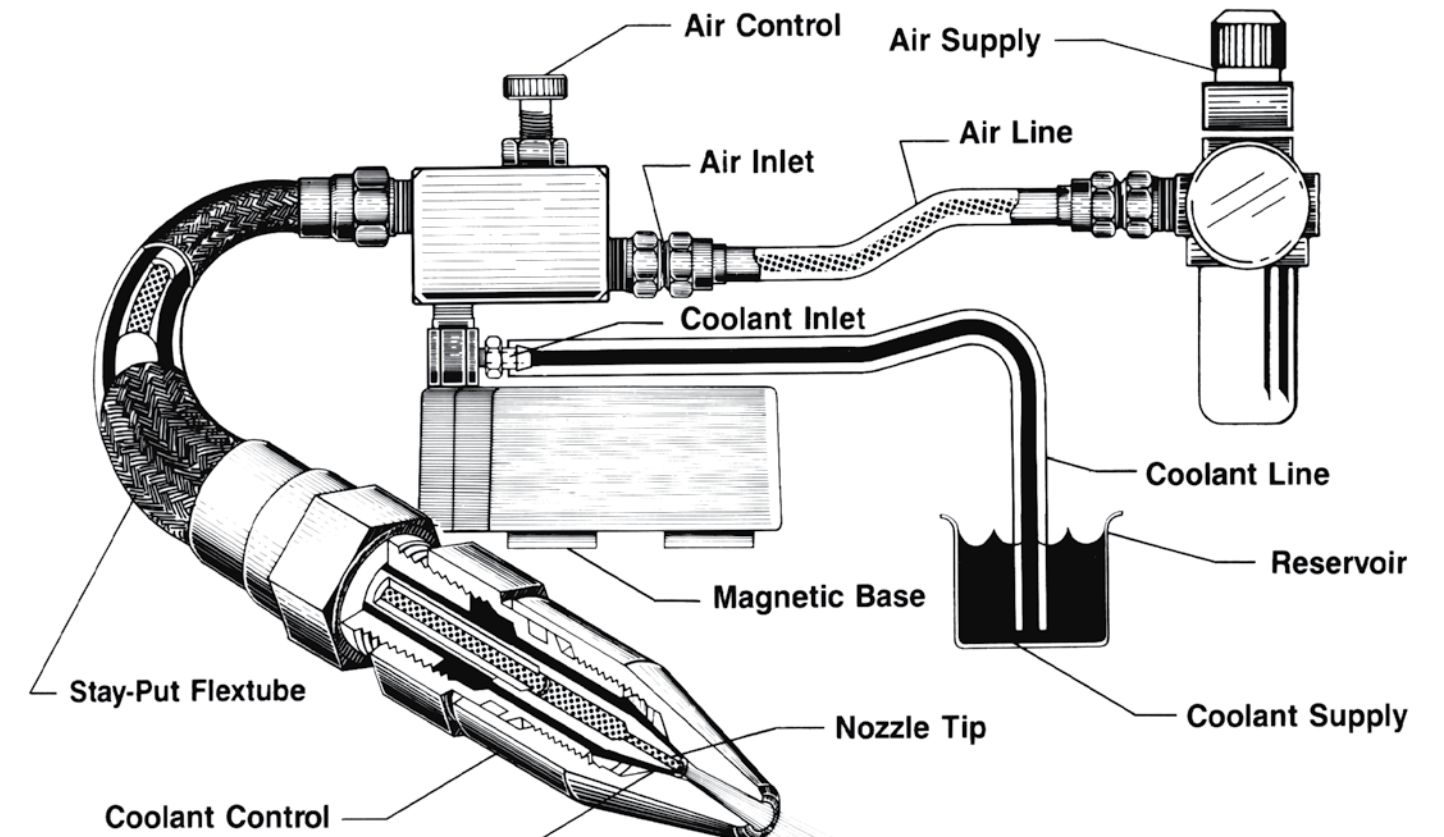

INSTALLATION INSTRUCTIONS

A. Mount the Mist Unit.

- If the Mist Unit has a **Magnetic Base**.
Set the Mist Unit at the location it is to be eventually used.
If the Mist Unit has no **Magnetic Base**.
Locate the Mist Unit where it is to be used, and attach it with #10 screws thru the holes provided.

B. Connect the Air Supply.

- Connect an **Air Line** from the **Air Supply** at the 1/8" NPT threaded port noted **Air Inlet** on the Mist Unit.
NOTE: It is found in most cases that a quick-tripping air valve on this line is quite handy. It allows easier on/off control of the Unit, keeping you from having to "turn" the Unit off with the Air Control each time and resetting the spray when "turning" it back on again.

C. Connect the Coolant Supply.

- Connect the **Coolant Line**, supplied with the Mist Unit, to the barbed fitting noted **Coolant Inlet**. Have the other end of this **Coolant Line** connected to, or placed into the **Reservoir** containing the Coolant.

OPERATING INSTRUCTIONS

The Mist Units all operate by the same principle. When air is supplied to the Mist Unit and the **Air Control** is "open", this air is supplied to the Mist Unit and exits at the **Nozzle Tip**. This air stream forms a venturi at the **Coolant Port** which places a suction on the **Coolant Supply**. The Coolant is drawn from its **Reservoir**, through the Mist Unit, and to the **Coolant Port** where it is atomized by the air stream to form the spray.

When the **Air Supply** is shut down, or the **Air Control** is closed, the spraying will stop. Turning the knob noted **Air Control** will regulate the amount of air used and the force of the spray. Rotating the knurled nozzle noted the **Coolant Control** will change the opening at the **Coolant Port** and regulate the amount of Coolant usage.

BasicMist Models
M-022 & M-023
MagnaMist Models
M-122 & M-123

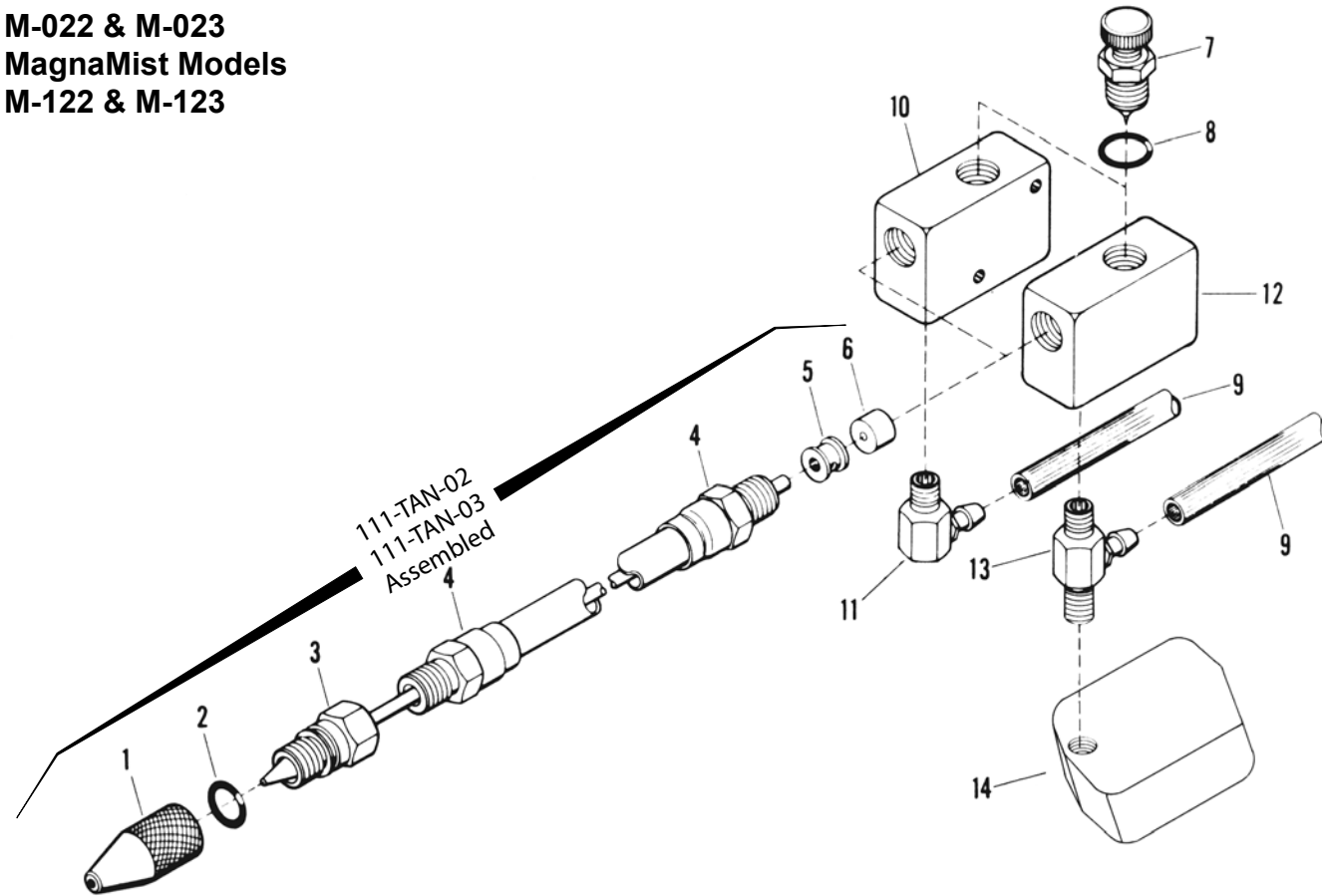

PARTS LISTING

KEY DESCRIPTION NO. Part Name or Reference	REPLACEMENT PART NUMBERS	
	Models with 9" FlexTubes	Models with 12" FlexTubes
Parts Below are Common to All Models (Listed at the Right)		
FlexTube:		
1 NOZZLE, Spray:	NOZ-003	NOZ-003
2 RING "O", Seal:	RGO-010	RGO-010
3 TUBE & HSG ASSY:	111-TAH-02	111-TAH-03
4 TUBE, Flex:	TUB-022	TUB-023
5 SPACER, Inlet:	SPC-001	SPC-001
6 SLEEVE, Rubber:	SLV-001	SLV-001
NOTE: Items above under "FlexTube" may be ordered assembled complete under Part 111-TUB-02, 111-TUB-03		
7 VALVE ASSY:	112-VAL-03	112-VAL-03
8 RING "O", Seal:	RGO-016	RGO-016
9 TUBE, Plastic:	TUB-154	TUB-154
Parts below are Common to Models with		
Magnetic Bases		
10 HOUSING, Valve:	HSG-042	HSG-042
11 INLET ASSEMBLY:	112-INL-01	1112-INL-01
Parts Below are Common to Models without		
Magnetic Bases		
12 HOUSING, Valve:	HSG-041	HSG-041
13 NLET ASSEMBLY:	121-INL-02	121-INL-02
14 BASE ASSY: Magnetic	282-BAS-06	282-BAS-06

BasicMist Model M-020

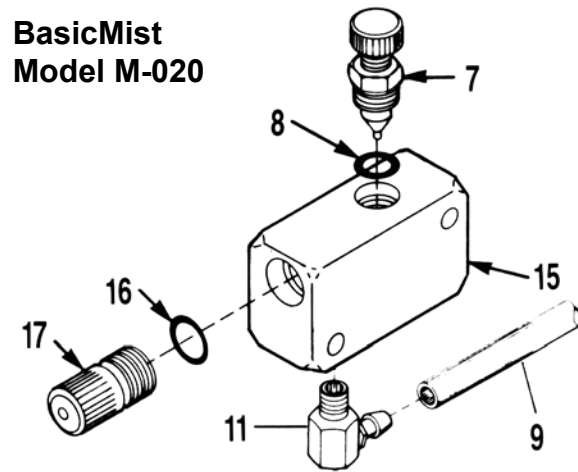

KEY NO.	DESCRIPTION Part Name or Reference	REPLACEMENT PART NUMBERS
7	VALVE ASSY: Thumb Screw	112-VAL-03
8	RING: "O" Seal	RGO-016
9	TUBE, Plastic: 5 ft	TUB154
11	INLET ASSY:	112-INL-01
15	HOUSING & INSERT ASSY:	112-HAI-01
16	RING, "O" Seal	RGO-010
17	NOZZLE, Spray	NOZ-006

TROUBLESHOOTING INSTRUCTIONS

PROBLEM	SOLUTION
I. Coolant drips from the Nozzle when the unit is turned off.	A. Coolant may be syphoning from the Reservoir. 1. Locate the Reservoir so that it's top is lower than the Nozzle Tip on the Unit.
II. The Spray flutters or comes out in intermittent bursts.	A. Air may be being drawn or forced into the Coolant. 1. Check for low Coolant level in the Reservoir. 2. Check all lines carrying Coolant for cracks, punctures, etc. Check that all line connections are tight and secure. 3. Remove NOZZLE (#1 on Parts List) by unscrewing it completely off. Check "O" RING (#2 on Parts List), replace if bad. Check inside NOZZLE for deformation or contamination, clean or replace if necessary. 4. Check that the FlexTube is tightly torqued into the HOUSING (#10 or #12 on Parts List). See PROBLEM V. for details on how tight. 5. Check the SLEEVE (#6 on the Parts List). Replace if cut or badly deformed. See PROBLEM V for instructions on disassembly.
III. Air is not being emitted from the Nozzle when Unit is turned on.	A. Air may not be getting to the Unit.. 1. Check if Air Control is "open". 2. Disconnect the Air Line at the Air Inlet on the Mist Unit and see if air flows from this Line when the Air Supply is turned on. B. An air passage in the Unit may be obstructed. 1. Turn air off using the Air Control. 2. Remove the FlexTube per the instructions given at PROBLEM V. 3. Turn air back on using the Air Control. a. If air flows from the unit, the blockage is in the FlexTube. b. If air does not flow from the Unit, the blockage is in the HOUSING (#10 or #12 on Parts List) or the Air Line to the Unit. c. See PROBLEM V. for instruction.
IV. Only air is emitted, no Coolant being	A. Coolant may not be getting to the Unit. 1. Make sure the Coolant Control is not "closed". This control can be used to shut off the Coolant Supply. 2. Check for low Coolant level in Reservoir. 3. Disconnect the Coolant Line at the Coolant Inlet on the Mist Unit. When the Mist Unit is "on", there should be a slight suction felt at the barbed Coolant Inlet. a. If no suction is seen, a Coolant passage in the Unit is probably obstructed. See step C. below. b. If there is suction, there is probably an obstruction in the Coolant Line or at the Reservoir. B. Air may be being drawn or forced into the Coolant. 1. See the SOLUTIONS at PROBLEM II. C. A Coolant passage may be obstructed. 1. Open the Air and Coolant Controls at least 2 turns. 2. Momentarily place thumb or finger over the end of Nozzle and release. If this solves the problem, the contamination has been dislodged. If this does not solve the problem or it re-occurs again quickly, see PROBLEM V.