

REPLACEMENT PARTS LISTING

MAIN PARTS LIST (reference Figure #3) for the MiniSpray Reservoir Modules P716-A & P717-A

The following parts are common to all MiniSpray Reservoir Modules

Key Part No.	No. Pcs	Description -or- Part Name
6	2	NUT, Hexagon: jam
7	2	RING, "O" type: seal
8	1	INLET, Sight:
9	2	RING, "O" type: seal
11	1	OUTLET, Sight:
12	1	RING, "O" type: seal
13	1	PLUG, Sight:
14	1	FILTER, Fluid:
15	1	FITTING, Elbow: barb
16	1	FITTING, Elbow: barb
17	1	OUTLET, Bulkhead:
18	1	RING, "O" type: seal
19	1	NUT, Special: jam
20	1	FITTING, Plug: pipe
21	1	OUTLET, Drain:
22	1	RING, "O" type: seal
23	1	NUT, Hexagon: jam
24	2	FITTING, Nut:
25	2	FITTING, Support: tube
26	1	TUBE, Plastic:
27	1	FITTING, Inlet:

The following parts are common to the MiniSpray Reservoir Module Model P716-A

Key Part No.	No. Pcs	Description -or- Part Name
1	1	RESERVOIR, Tank:
2	1	COVER, Tank:
3	4	BRACKET, Mounting:
4	4	RING, "O" type: seal
5	4	NUT, Jam: locking
10	1	PIPE, Plastic: sight
28	1	TUBE, Plastic:
**A	1	MiniSpray Module

The following parts are common to the MiniSpray Reservoir Module Model P717-A

Key Part No.	No. Pcs	Description -or- Part Name
1	1	RESERVOIR, Tank:
2	1	COVER, Tank:
3	4	BRACKET, Mounting:
4	4	RING, "O" type: seal
5	4	NUT, Jam: locking
10	1	PIPE, Plastic: sight
28	1	TUBE, Plastic:
**A	1	MiniSpray Module

** See MAIN PARTS LIST for the MiniSpray Module for further breakdown of parts.

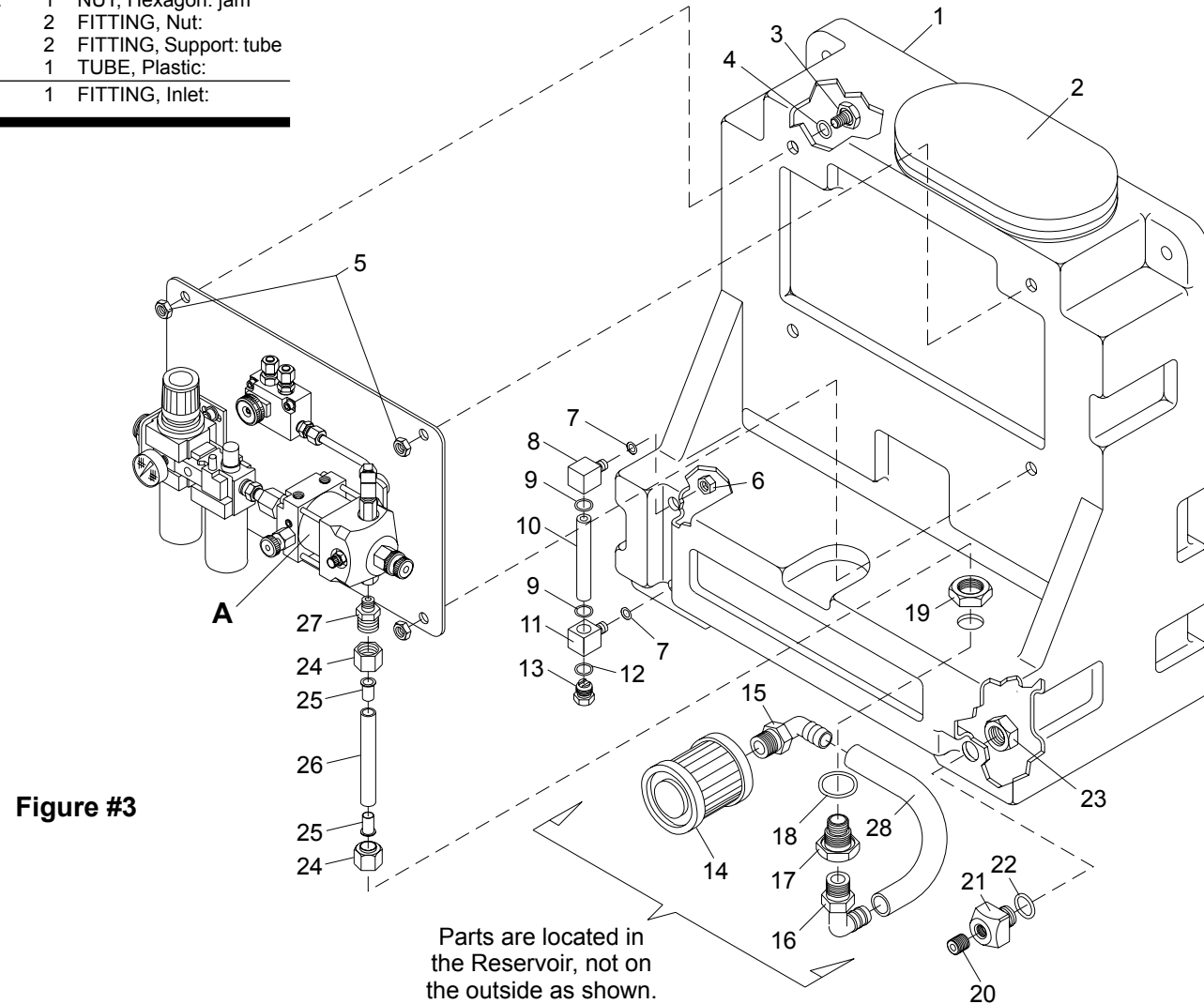

Figure #3

Parts are located in the Reservoir, not on the outside as shown.

INSTALLATION, OPERATION, and TROUBLESHOOTING

with REPLACEMENT PARTS LISTING for the MiniSpray Module Model **P-710-A, P-716-A & P-717-A** Supercedes P-710, P-716 & P-717



P.O. Box 5303, ROCKFORD, IL • 61125
2511-20TH ST., ROCKFORD, IL • 61104
TEL: 815-226-8090 • FAX: 815-226-9250
E-MAIL: SALES@LSPIND.COM

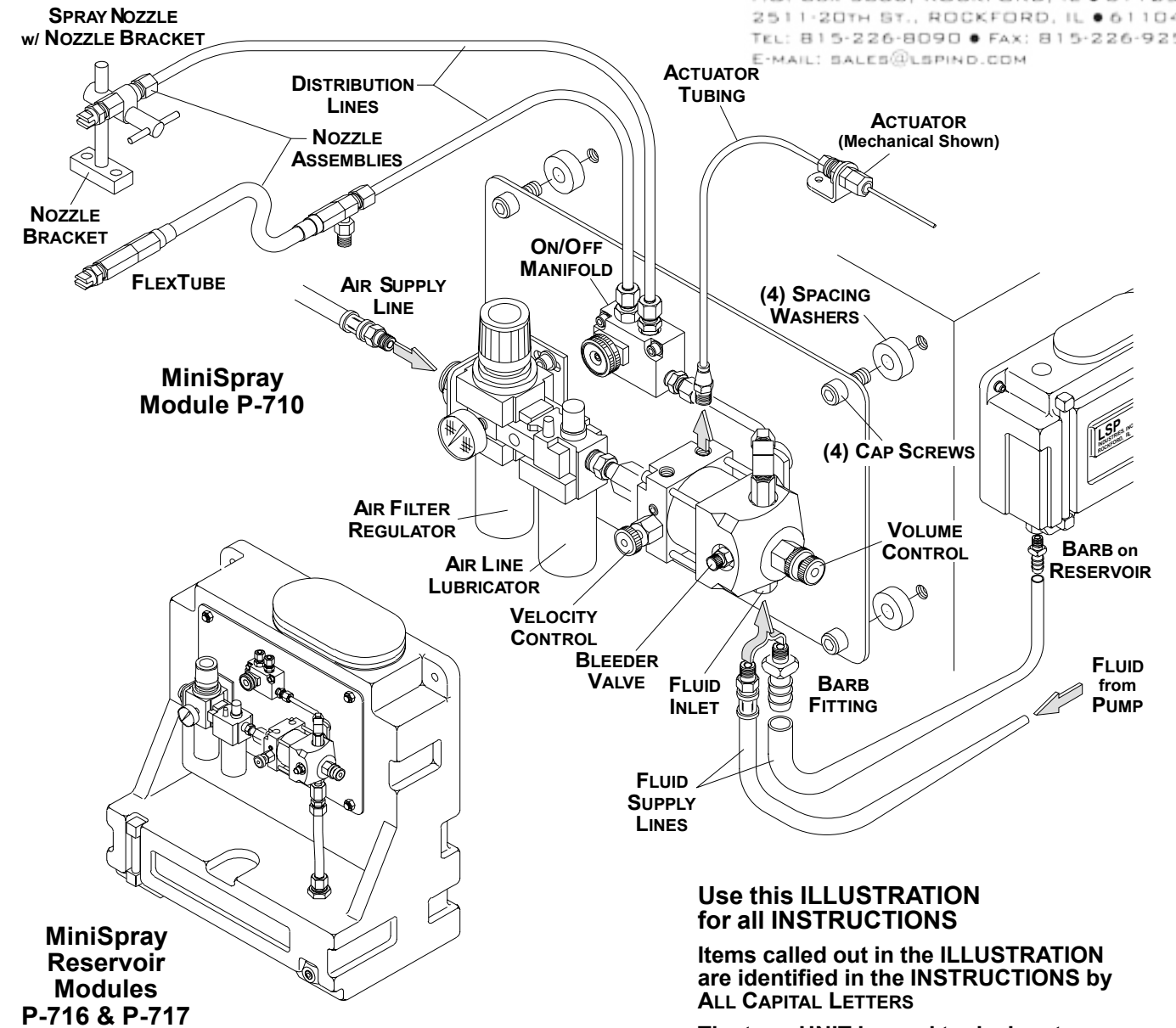

Use this ILLUSTRATION for all INSTRUCTIONS

Items called out in the ILLUSTRATION are identified in the INSTRUCTIONS by ALL CAPITAL LETTERS

The term UNIT is used to designate the entire MicroSpray Module

SUPPLEMENTAL INSTRUCTIONS

These INSTRUCTIONS rely heavily on information found in supplemental Instruction Sheets. Before starting, make sure that the **INSTALLATION, OPERATION, and TROUBLESHOOTING** Instructions with the following subtitles are available for reference.

- for the MiniSpray Model No. P-040-A
Describes the operation and maintenance of the MiniSpray. The MiniSpray provides the lubricant spraying function.
- for the On/Off Manifold Model P-922
Describes using the **ON/OFF MANIFOLD** to split-up and control the **DISTRIBUTION LINES**.
- for the (appropriate ACTUATOR chosen)
Describes the device chosen to actuate the **UNIT**. There are a variety of these. You must have one to operate the **UNIT**,

and along with it, must have its Instruction Sheet. If any of the Instruction Sheets called for above are missing, they must be located. If they cannot be found, request replacements for whichever is missing from L.S.P.

These supplemental Instruction Sheets will be necessary for proper installation and maintenance of the **UNIT**, always keep them attached to these Instructions.

NOTE:
These Instructions cover three different Model Units. Most of the data herein pertains to all; however, should a paragraph only pertain to specific Models, that paragraph will begin "Only for Model No...." and give the respective Model Number(s) for that **UNIT**.

06-01-2011

INSTALLATION INSTRUCTIONS

A. Installing the Actuator

See the Instruction Sheet for the **ACTUATOR** you have chosen to use. Follow the given **INSTALLATION INSTRUCTION** supplied with that **ACTUATOR**.

If you have no **ACTUATOR**, see the **ACCESSORIES** Section of the **MiniSpray** Instruction Sheet for a list of those available.

B. Installing the UNIT

See the **MiniSpray's** Instruction Sheet under the heading **Installing the MiniSpray**.

1. Locating the UNIT

Consider the suggestions given for the **MiniSpray** under the similar heading. The same applies for this **UNIT**.

2. Mounting the UNIT

Only for Model No. P710-A. Drill and tap for four 1/4-20 screws on center with the holes in the **MOUNTING PLATE**.

Use the **SPACING WASHERS** supplied to keep the **PLATE** away from the mounting surface (done to relieve for protrusions on the back side of the **PLATE**).

Insert screws through the holes and washers, and torque securely into the tapped holes.

Only for Model No. P716-A or P717-A. The **UNIT** can be simply set into place on the feet provided by the **RESERVOIR**, or can be mounted on a wall using the holes provided in the tabs of the **RESERVOIR**.

For wall mounting; drill and tap for two 1/4-20 screws on center with holes in **RESERVOIR**. Insert screws and torque.

C. Installing the Fluid Supply

Only for Model No. P710-A. See the **MiniSpray's** Instruction Sheet under the similar heading. Use the appropriate area in the instructions (for using a **RESERVOIR** or **PUMP**).

Only for Model Nos. P716-A & P717-A. A **RESERVOIR** is included with these **UNITs**, which is simply filled with the lubricant.

D. Installing Air Supply

See the **MiniSpray's** Instruction Sheet under the same heading. The same principles apply for this **UNIT**.

The **AIR FILTER/REGULATOR/LUBRICATOR** which is recommended in the Instruction is included with this **UNIT**. The **AIR SUPPLY** is to be connected at it's **AIR INLET PORT** as illustrated.

E. Installing the Distribution System

See the **MiniSpray's** Instruction Sheet under the same heading.

OPERATING INSTRUCTIONS

All operation concerning the spraying of the lubricant is the same as described in the **MiniSpray's OPERATING INSTRUCTION**. Follow the instructions given therein.

All operation concerning the control of the **UNIT** is described in the **OPERATING INSTRUCTIONS** for the chosen **ACTUATOR**. Follow the instructions given therein.

TROUBLESHOOTING

See the appropriate **TROUBLESHOOTING INSTRUCTIONS** for the **MiniSpray** or **ACTUATOR** depending on the type of problem to be solved.

Use the **REPLACEMENT PARTS LISTING** at the left and at the back for parts not found in the other Instructions.

REPLACEMENT PARTS LISTING

MAIN PARTS LIST (reference Figure #1) for the MiniSpray Modules The following parts are common to all the MiniSpray Modules

Key Part No.	No. Number	No. Pcs	Description -or- Part Name
1	PLT061	1	PLATE, Mounting
2	SPC016	2	SPACER, Mounting:
3	WAS003	4	WASHER, Plain: 1/4"
4	SCR035	2	SCREW, Cap:
5	FIT015	1	FITTING, Elbow:
6	TUB302	1	TUBE, Copper:
7	FIT021	1	FITTING, Adapter:
8	WAS001	2	WASHER, Lock: #10
9	SCR023	2	SCREW, Cap:
10	459BRK01	1	BRACKET, Union: pipe
11	FIT054	1	FITTING, Bushing: pipe
12	ADP065	1	ADAPTER, Mounting:
13	NUT168	2	NUT, Jam: special
14	BRK039	1	BRACKET, Mount:
15	SCR075	2	SCREW, Cap:
A	220-EJT-01	1	MiniSpray Unit
B	290-MAN-071	1	On/Off Manifold
C	REG-007	1	Air Regulator/Oiler

The following parts are common to the P710-A MiniSpray only.

Key Part No.	No. Number	No. Pcs	Description -or- Part Name
1	PLT061	1	PLATE, Mounting:
16	SPC016	4	SPACER, Mounting:
17	SCR011	4	SCREW, Cap:

The following part is common to the P716-A MiniSpray only.

Key Part No.	No. Number	No. Pcs	Description -or- Part Name
1	PLT061	1	PLATE, Mounting:

The following part is common to the P717-A9 MiniSpray only.

Key Part No.	No. Number	No. Pcs	Description -or- Part Name
1	PLT062	1	PLATE, Mounting:

PART LIST "B" 290-MAN-09 Manifold Assembly

(reference Figure #2)

Key Part No.	No. Number	No. Pcs	Description -or- Part Name
1	SCR-060	1	SCREW, Button Head
2	MLD-051	1	MOLDING, Knob: small
3	SCR-086	2	SCREW, Cap: soc hd.
4	PLT-071	1	PLATE, Retainer: small
5	RGB-032	1	RING, Backup: solid
6	RGO-057	1	RING, "O": seal.
7	STM-002	1	STEM, Valve: on/off.
8	HSG-226	1	HOUSING, Valve.
9	SET-036	2	SEAT, Valve: on/off
10	BAL-052	1	BALL, Valve: on/off.
11	OUT-014	1	OUTLET, Valve
12	FIT-017	1	CAP, 1/4 comp.
13	FIT-021	1	FITTING, Adapter

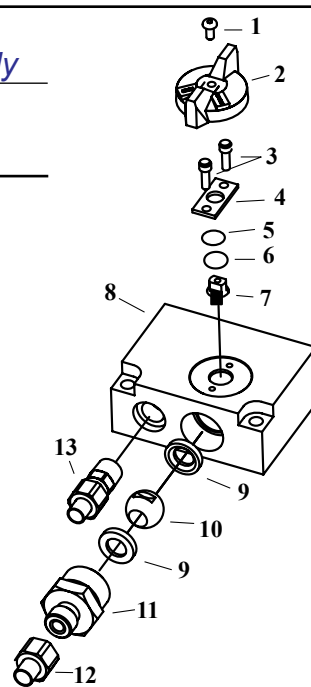
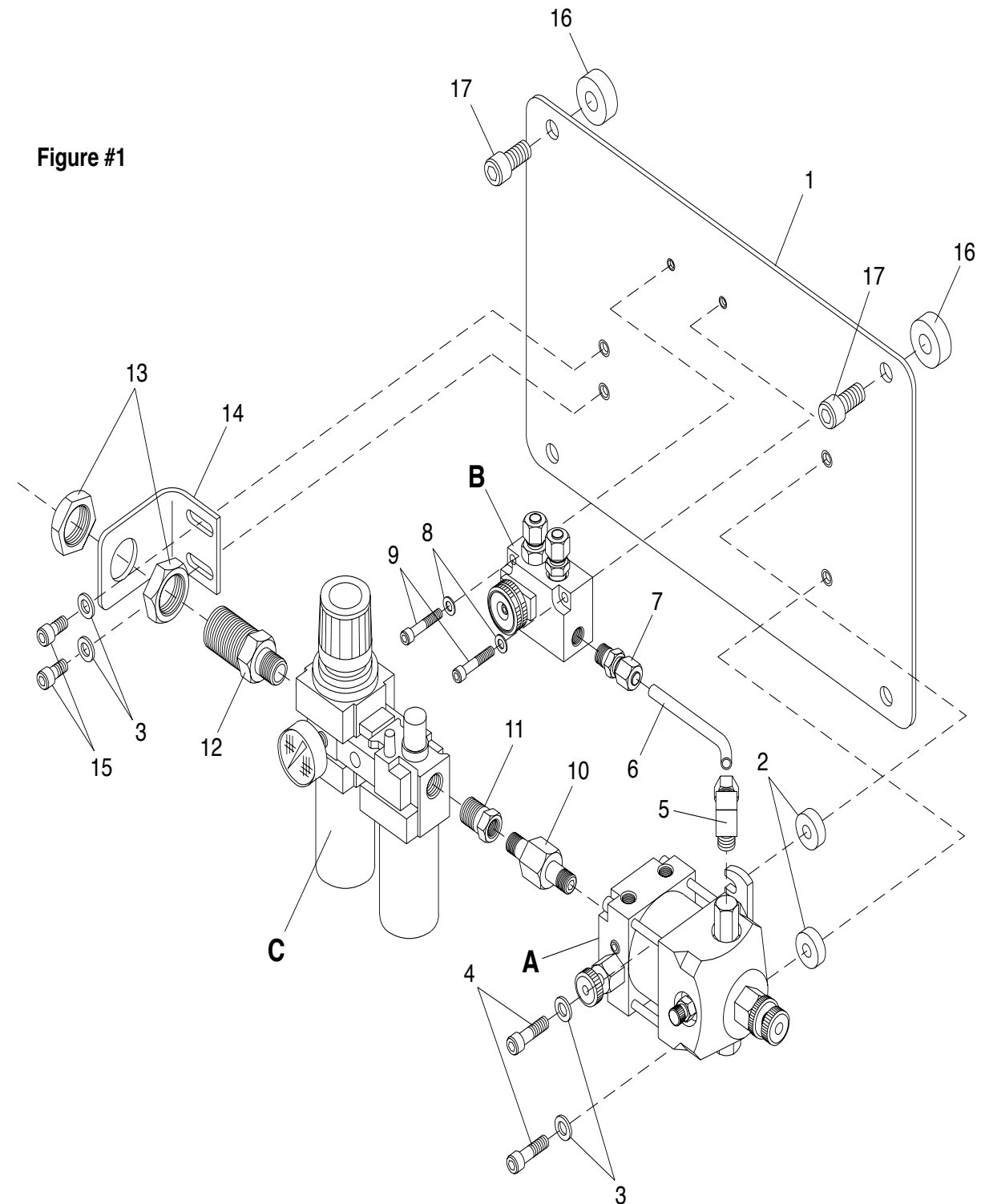

Figure #1



PART LIST "C" REG-019 Air Handling Includes all except GAU-001 (reference Figure #2)

Key Part No.	No. Number	No. Pcs	Description -or- Part Name
1	ACY028	1	BONNET, Regulator:
2	GAU001	1	GAUGE, Pressure:
3	RGO074	2	RING, "O" type: seal
4	ACY026	2	BOWL, Filter/Oiler:
5	RGO067	2	RING, "O" type: seal
6	ACY032	1	ACCESSORY, Spacer: brk
7	ACY029	1	BONNET, Oiler:
8	ACY022	1	DOMES, Oiler:

