

INSTALLATION, OPERATION, and TROUBLESHOOTING

with REPLACEMENT PARTS LISTING
for the Mechanical Actuator P-901



P.O. Box 5303, 2511-20th St.
Rockford, Illinois 61125
815/226-8090 Fax: 815/226-9250
E-Mail: lsp@lspind.com

Use this Illustration for all Instructions

**Relief Port
of UniValve**

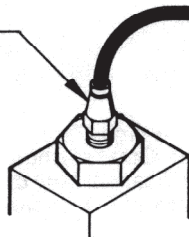

TRIP-BRACKET

WAND

JAM NUT

**ACTUATOR
TUBING**

L-BRACKET

3/4" to 1-1/2"
Wand deflection

3/16" to 3/8"
Wand engagement

Wand deflection
just enough to let
Trip-Bracket past

Items called out in ILLUSTRATION
are shown in the INSTRUCTIONS
with ALL CAPITAL LETTERS

The term "UNIT" is used to designate
a Part with a UniValve.

OPERATING INSTRUCTIONS

The MECHANICAL ACTUATOR may be used to actuate the UniValve on any LSP UNIT. It operates by having its WAND deflected off-center in any direction. Locating it where some part of the machinery will trip it, makes its operation automatic. See Fig. #1 for commonly used tripping methods.

WAND Travel

The WAND must be deflected at least 7/8" to fully open the Actuator. If no movement this large is available, a shorter travel may be used if the WAND is modified (see MODIFICATIONS).

WAND Pick-Up

NOTE: The following dimensions only pertain to an un-modified WAND.

If 1/8" to 3/8" of the WAND is picked-up, it will be deflected 7/8" to 1-1/2" respectively. If more than 7/16" is picked-up, the WAND will be deflected past its limit, and may bend or break.

Adjustment

Pick-up can be adjusted for by screwing the ACTUATOR back or forth in its L-BRACKET. After adjusting, lock in place using the JAM NUT.

INSTALLATION INSTRUCTIONS

Locating the ACTUATOR

There may be many places the ACTUATOR can be located. The following will help in selecting the best one.

A. Locate as close to the UNIT as practical.

The ACTUATOR must be within four feet of the UNIT to use the ACTUATOR TUBE supplied. This distance may have to be less to operate at very fast cycle rates. If absolutely necessary, a longer TUBE might be used, but only if the application allows (see MODIFICATIONS).

B. Route the ACTUATOR TUBE out of harms way.

Keep it out of areas where it might interfere with operation. Also keep it away from machinery that might catch or rub it.

C. Select a location that is sound.

Once mounted the ACTUATOR should not move. Do not mount on sheet metal, guards, doors, etc.

D. Consider adjusting for setups.

If the Trip-Point will be changing from one setup to another, consider using an LSP MagnaBase or making an adjustable bracket to hold the ACTUATOR or TRIP-BRACKET.

Using the TRIP-BRACKET

The TRIP-BRACKET is included to convert any moving surface to a Trip-Point. It also solves the problem of double-tripping when using a back and forth movement.

This BRACKET has a V-groove to catch and deflect the WAND as it passes by going in one direction. Going the opposite direction, it only moves the WAND far enough to get past, but not enough to operate the ACTUATOR.

Figure #1

Tripping the Actuator

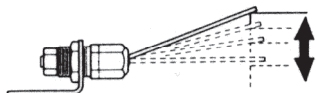

One end of a back/forth motion may be used for actuating at the end of a stroke.

Use the Trip-Bracket to actuate in the middle of a back/forth motion. It will allow actuation without double-tripping.

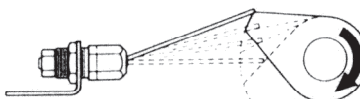
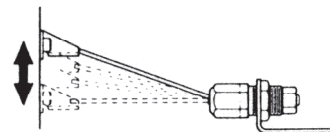

A rotating motion may be used for actuation by attaching a cam. Time of actuation is set by adjusting the cam location.

INSTALLATION (continued)

Mounting the Actuator

Position the Actuator at the Trip-Point and mount using the two #10-32 screws through the holes in the L-Bracket.

Installing the Actuator Tube

The 3/16" O.D. plastic Actuator Tube gets installed between the Actuator and UniValve as follows:

1. Insert one end of the Tube into the hole in back of the Actuator, and push in until it bottoms in the fitting.
2. Route the other end of the Tube to the Relief-Port on the UniValve. Take as much slack out of the Tube as possible without causing sharp bends, kinks, or crimps in it. Cut the Tube off squarely at this length.
3. Insert the Tube into the Relief-Port and push in until bottomed.

Dis-connecting the Tube

To dis-connect the Tube from these push-in fittings, press down on the collar around the Tube where it enters the fitting. While this collar is held down, the Tube may be pulled out.

MODIFICATIONS

Using a Short Travel

The amount of travel required to open the Actuator may be decreased by simply shortening the Wand. Never shorten a WAND any more than necessary. As seen below, tolerances and adjustments are decreased proportionately.

Eg: If a WAND is cut to half it's original length, all setup dimensions are also halved. This ACTUATOR will now open at 7/16" of travel, which happens if 1/16" of the WAND is picked-up. And now the WAND may be damaged if more than 7/32" is picked-up.

Using a Longer ACTUATOR TUBE

Never plan on using a longer ACTUATOR TUBE until assured it will work. Depending on the UNIT, there is a limit on how long a TUBE may be without giving poor performance.

Always check operation with a TUBE at least a foot longer than you plan on using. Then, if operation is satisfactory, cut it to the shorter length for use.

Using Other ACTUATORS

The MECHANICAL ACTUATOR was included with your UNIT to afford a method to actuate it. Other methods are available that may be more suitable to your application. Any of the ACTUATORS described below maybe used in place of the MECHANICAL ACTUATOR.

1. Solenoid Actuator

Operates on a 110 VAC electrical signal. Can be used with a limit switch, or through your machine controller if available.

2. Air Timer Actuator

Operates with air. Will actuate the UNIT at a setable time cycle. Repeats the timed cycle continuously until the air is removed.

3. Electronic Controller

Operates by Magnetic-Pickup. Gives complete control of the operation using simple switches and calibrated dials. Makes setup and adjustment easy and quick.

REPLACEMENT PARTS LISTING

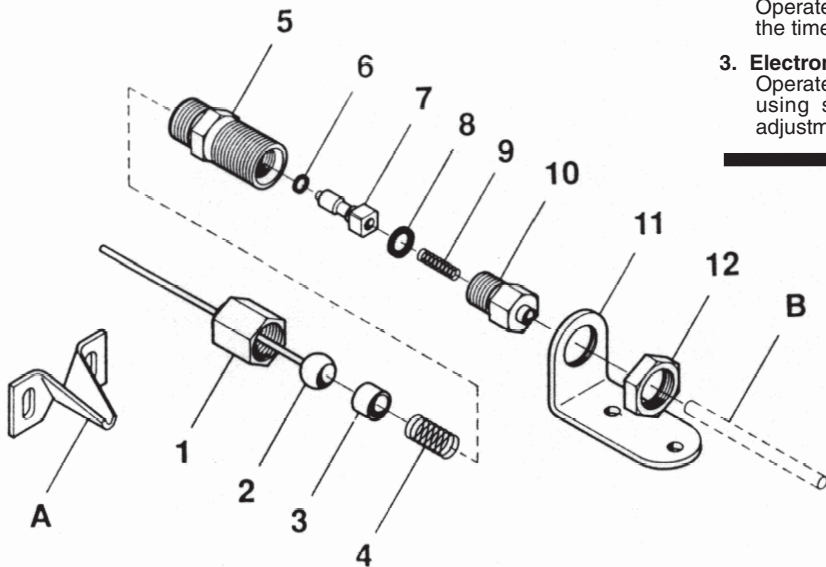

Key	Part No.	Pieces	Description
1	RET-002	1	RETAINER,Cap:
2	290-CAM-01	1	CAM ASSEMBLY:
3	GID-011	1	GUIDE,Spring:
4	SPG-026	1	SPRING,Cam:
5	HSG-062	1	HOUSING,Valve:
6	RGO-009	1	"O" Ring, Seal:
7	SPL-021	1	SPOOL, Valve:
8	RGO-020	1	"O" RING,Seal:
9	SPG-025	1	SPRING, Spool:
10	290-INL-01	1	INLET FITTING:
11	BRK-033	1	BRACKET, Mounting:
12	NUT-164	1	NUT, Jam; special
A	BRK-015	1	TRIP BRACKET
B	TUB-019	1	TUBE, Actuator:

TROUBLESHOOTING INSTRUCTIONS

PROBLEMS	SOLUTIONS
Wand does not return to center after tripping.	<ol style="list-style-type: none"> 1. Check for a broken Spring(4) in front, or Spring(9) in back of the Actuator. 2. Check if the Cam(2), the Guide(3), or the area around them is dirty or shows wear or deformation. Clean or replace as required.
Actuator expels air continually.	<ol style="list-style-type: none"> 1. Check if the "O"Ring(6) is sealing. If cut or worn, replace it. 2. See if the Spool(7) moves freely into the Housing(9) until it seats. Clean these parts if dirty, replace if worn or deformed.
Actuator does not work. (does not expel air when it is tripped)	<ol style="list-style-type: none"> 1. See if the ACTUATOR TUBE is clogged. Dis-connect it from the ACTUATOR and check for air flow. 2. Remove Spool(7) and see if "O"Ring(6) is out of it's groove. If so, this "O"Ring is probably bad.